

422

Hydraulic Swing Gate Operator



UL325 Compliant

FAAC International Inc.
Headquarter & East Coast Operations
3160 Murrell Road
Rockledge, FL 32955
Tel. 800 221 8278
www.faacusa.com

FAAC International Inc.
West Coast Operations
357 South Acacia Avenue
Fullerton, CA 92831

FAAC

TABLE OF CONTENTS

IMPORTANT SAFETY INFORMATION	3
Important Safety Instructions	3
Important Installation Instructions	3
General Safety Precautions	4
UL325 Gate Operator Classifications	5
Installing the Warning Signs	5
1. DESCRIPTION TECHNICAL SPECIFICATIONS	6
1.1 Dimensions	6
1.2 Wiring	6
2. INSTALLATION	7
2.1. Preliminary Checks	7
2.2. Installation Dimensions	7
2.3 General Rules	7
2.4. Installation of the Operator	7
2.5. By-Pass valves adjustment	10
3. MANUAL OPERATION	10
4. MAINTENANCE AND REPAIRS	11
5. SPARE PARTS	12
422 CBAC	12
Cylinder	13
455D CONTROL BOARD	
1. General Description	A2
2. Technical Specification	A2
3. Features	A2
4. Layout and Components	A2
5. Electric Connections	A3
6. Connection of Safety Devices	A4
7. Operating Logics	A6
8. Programming	A6
9. Start-up	A8
10. Learning Operating Times	A9
11. Final Tests	A9
12. Operating Modes Detailed Description	A10
13. Prewired Enclosure	A12
Limited Warranty	A16

IMPORTANT SAFETY INFORMATION

Important Safety Instructions



WARNING: TO REDUCE THE RISK OF SEVERE INJURY OR DEATH:

- READ AND FOLLOW ALL INSTRUCTIONS.
- Never let children operate or play with the gate controls. Keep remote controls away from children.
- Always keep people and objects away from the gate. NO ONE SHOULD CROSS THE PATH OF A MOVING GATE.
- Test the gate operator monthly. The gate MUST reverse on contact with a rigid object or when an object activates a non-contact sensor. If necessary, adjust the force or the limit of travel and then retest the gate operator. Failure to properly adjust and retest the gate operator can increase the risk of injury or death.
- Use the manual release mechanism only when the gate is not moving.
- KEEP GATE PROPERLY MAINTAINED. Have a qualified service person make repairs to gate hardware.
- The entrance is for vehicles only. Pedestrians must use a separate entrance.
- SAVE THESE INSTRUCTIONS.

Important Installation Instructions

1. Install the gate operator only when the following conditions have been met:
 - The operator is appropriate for the type and usage class of the gate.
 - All openings of a horizontal slide gate have been guarded or screened from the bottom of the gate to a minimum of 4 feet (1.25 m) above the ground to prevent a 2.25 inch (55 mm) diameter sphere from passing through openings anywhere in the gate or through that portion of the adjacent fence that the gate covers when in the open position.
 - All exposed pinch points are eliminated or guarded.
 - Guarding is supplied for exposed rollers.
2. The operator is intended for installation on gates used by vehicles only. Pedestrians must be provided with a separate access opening.
3. To reduce the risk of entrapment when opening and closing, the gate must be installed in a location that allows adequate clearance between the gate and adjacent structures. Swinging gates shall not open outward into public access areas.
4. Before installing the gate operator, ensure that the gate has been properly installed and that it swings freely in both directions. Do not over-tighten the operator clutch or pressure relief valve to compensate for a damaged gate.
5. User controls must be installed at least 6 feet (1.83 m) away from any moving part of the gate and located where the user is prevented from reaching over, under, around or through the gate to operate the controls. Controls located outdoors or those that are easily accessible shall have security features to prevent unauthorized use.
6. The Stop and/or Reset buttons must be located within line-of-sight of the gate. Activation of the reset control shall not cause the operator to start.
7. All warning signs and placards must be installed and easily seen within visible proximity of the gate. A minimum of one warning sign shall be installed on each side of the gate.
8. For gate operators that utilize a non-contact sensor (photo beam or the like):
 - See instructions on the placement of non-contact sensors for each type of application.
 - Exercise care to reduce the risk of nuisance tripping, such as when a vehicle trips the sensor while the gate is still moving.
 - Locate one or more non-contact sensors where the risk of entrapment or obstruction exists, such as at the reachable perimeter of a moving gate or barrier.
 - Use only FAAC "Photobeam" photoelectric eyes to comply with UL325.
9. For gate operators that utilize a contact sensor (edge sensor or similar):

Important Installation Instructions (continued)

- Locate one or more contact sensors where the risk of entrapment or obstruction exists, such as at the leading edge, trailing edge, and post mounted both inside and outside of a vehicular horizontal slide gate
- Locate one or more contact sensors at the bottom edge of a vehicular vertical lift gate.
- Locate one or more contact sensors at the bottom edge of a vertical barrier (arm).
- Locate one or more contact sensors at the pinch point of a vehicular vertical pivot gate.
- Locate hard-wired contact sensors and wiring so that communication between sensor and gate operator is not subjected to mechanical damage.
- Locate wireless contact sensors, such as those that transmit radio frequency (RF) signals, where the transmission of signals are not obstructed or impeded by building structures, natural landscaping or similar hindrances. Wireless contact sensors shall function under their intended end-use conditions.
- Use only FAAC MSE MO, CN60 or M60 edge sensors.

**General Safety Precautions**

Gate Construction

Vehicular gates should be constructed and installed in accordance with ASTM F2200: Standard Specification for Automated Vehicular Gate Construction.

For more information, contact ASTM at: www.astm.org

Installation

- If you have any questions or concerns regarding the safety of the gate operating system, do not install the operator and consult the manufacturer.
- The condition of the gate structure itself directly affects the reliability and safety of the gate operator.
- Only qualified personnel should install this equipment. Failure to meet this requirement could cause severe injury and/or death, for which the manufacturer cannot be held responsible.
- The installer must provide a main power switch that meets all applicable safety regulations.
- It is extremely unsafe to compensate for a damaged gate by increasing hydraulic pressure.
- Install devices such as reversing edges and photo beams to provide better protection for personal property and pedestrians. Install reversing devices that are appropriate to the gate design and application.
- Before applying electrical power, ensure that voltage requirements of the equipment correspond to the supply voltage. Refer to the label on your gate operator system.

Usage

- Use this equipment only in the capacity for which it was designed. Any use other than that stated should be considered improper and therefore dangerous.
- The manufacturer cannot be held responsible for damage caused by improper, erroneous or unreasonable use.
- If a gate system component malfunctions, disconnect the main power before attempting to repair it.
- Do not impede the movement of the gate, you may injure yourself or damage the gate system as a result.
- This equipment may reach high thermal temperatures during normal operation, therefore use caution when touching the external housing of the gate operator.
- Use the manual release mechanism according to the procedures presented in this manual.
- Before performing any cleaning or maintenance operations, disconnect power to the equipment.
- All cleaning, maintenance or repair work must be performed by qualified personnel.

UL325 Gate Operator Classifications

RESIDENTIAL VEHICULAR GATE OPERATOR CLASS I

A vehicular gate operator system intended for use in a single family dwelling, garage or associated parking area.

COMMERCIAL / GENERAL ACCESS VEHICULAR GATE OPERATOR CLASS II

A vehicular gate operator system intended for use in commercial locations or buildings such as multi-family housing units (five or more single family units), hotels, parking garages, retail stores or other buildings that service the general public.

INDUSTRIAL / LIMITED ACCESS VEHICULAR GATE OPERATOR CLASS III

A vehicular gate operator system intended for use in industrial locations or buildings such as factories, loading docks or other locations not intended to service the general public.

RESTRICTED ACCESS VEHICULAR GATE OPERATOR CLASS IV

A vehicular gate operator system intended for use in guarded industrial locations or buildings such as airport security areas or other restricted access locations that do not service the general public, and in which unauthorized access is prevented via supervision by security personnel.

Installing the Warning Signs

This FAAC swing gate operator is supplied with two warning signs to alert people that a possible hazard exists and that appropriate actions should be taken to avoid the hazard or to reduce exposure to it.

Permanently install one warning sign on each side of the gate so they are fully visible to traffic and pedestrians.

Use appropriate hardware such as metal screws (not supplied) to permanently install each warning sign.



422 OPERATOR

The self contained 422 operator is an electro-hydraulic unit consisting of an electric motor, a pump, a valve assembly and a hydraulic cylinder, all housed in an anodized aluminum oil reservoir.

The standard model of the 422 operator (CBAC) comes with hydraulic locks in both open and close positions. The optional SB version doesn't have any locks.

The hydraulic lock is a service device rather than a security device. Additional external locks are recommended if tight security is needed.

The 422 operator is designed and built to automate vehicular swing leaf gates. Do not use for any other purpose.

1. DESCRIPTION AND TECHNICAL SPECIFICATIONS

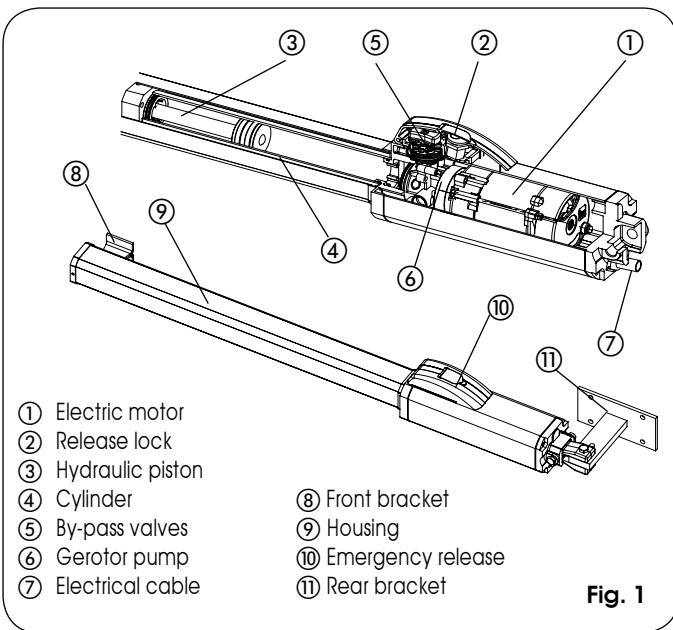

Tab. 1: Technical specifications

Input voltage	115Vac (+10% -6%) or 230Vac (+6% -10%)
Rod extension speed	0.5 in/sec (1.3 cm/s)
Pump flow rate	1 l/min
Traction and thrust force	1124 lbf (500 daN)
Operating ambient temperature	4°F +131°F (-20 °C +55°C)
Power	220 W
Current	2A (115V) - 1A (230V)
Motor rotation speed	1400 rpm
Thermal protection	120°C
Weight	15.4 lb (7 kg)
Type of oil	FAAC HP OIL
Protection class	IP 55
Leaf max width	10 ft (3m)
Leaf min width	7.5 ft (2.3 m)
Leaf max weight	900 lb (410 Kg)
Use frequency	55 (cycles/hour)

1.1. DIMENSIONS

Fig. 2

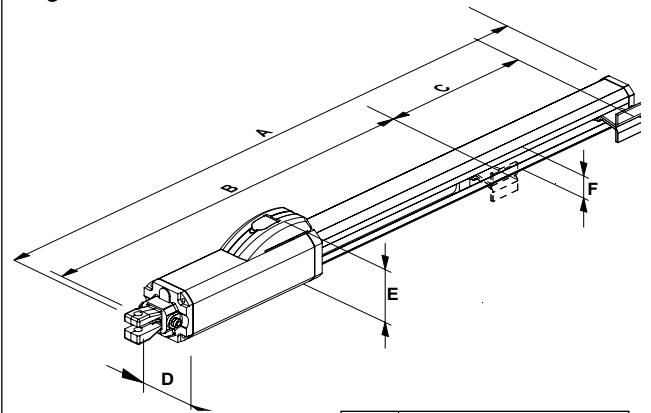

A	38.85 in (987 mm)
B	27.3 in (693 mm)
C	9.5 in (240 mm)
D	3.3 in (85 mm)
E	4.7 in (120 mm)
F	2.4 in (61 mm)

1.2. WIRING

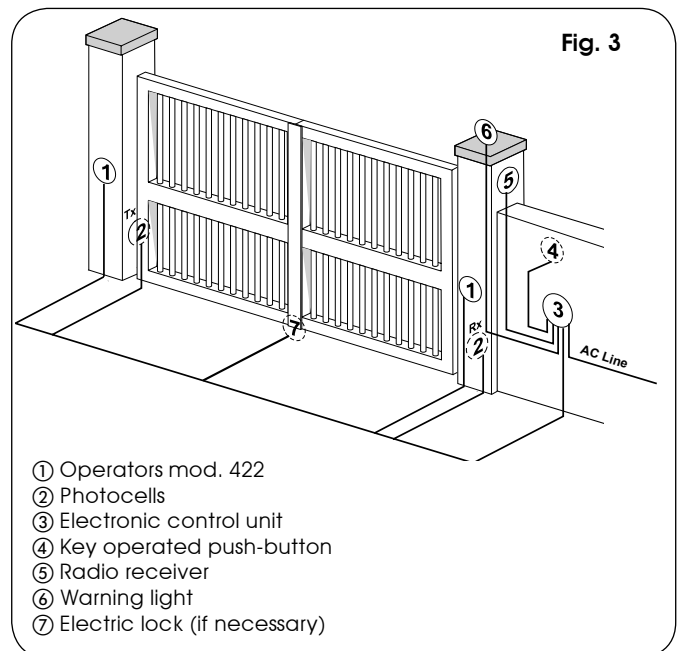

Always separate the connection cables of the low voltage accessories from the high voltage power cables. Use separate conduits to avoid interference.

The installer is responsible for grounding the gate and operator systems, for providing the main power breaker switch, and for making sure that the entire gate system meets all applicable electrical codes.

Make sure to locate all controls that operate the gate system at least 6 ft away from any moving parts.

2. INSTALLATION

2.1. PRELIMINARY CHECKS

To ensure a correctly operating automated system, the structure of the existing gate or gate to be built must satisfy the following requirements:

- Leaf dimensions are within the limits specified in Table 1
- The gate swings level
- Smooth, uniform leaf movement, without any irregular friction during the entire travel
- Existing hinges in good condition
- Positive stops are provided in the fully opened and closed positions

2.2. INSTALLATION DIMENSIONS

Inward swinging gate, top view

Fig. 4a

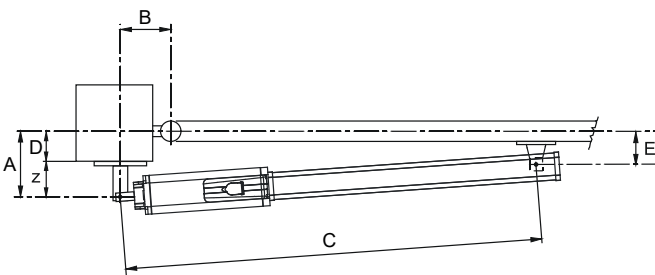

Opening angle	A	B	C
90°	4 3/4	4 3/4	36 3/4
110°	4	4	36 3/4

D : If greater that 2 in. a recess must be constructed
E : Must be less than A
Z : Must be 2 in. minimum to avoid mechanical interference

Outward swinging gate, top view

Fig. 4b

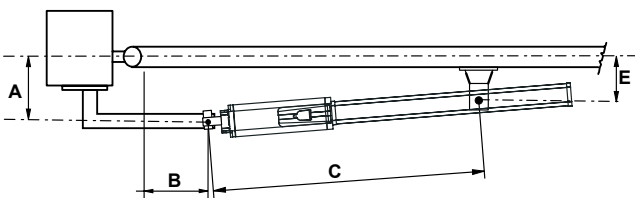

Opening angle	A	B	C
90°	4 3/4	4 3/4	27 1/4

E : Must be less than A

2.3. GENERAL RULES

If the dimensions indicated in table A or B cannot be obtained the following general rules can be used determine different installation dimensions:

- to obtain 90° opening of the leaf: $a + b = \text{rod stroke}$.
- to obtain over 90° opening of the leaf: $a + b < \text{rod stroke}$.
- lower a and b dimensions will result in higher speeds.
- limit the difference of the a and b dimensions to within 1.5 in, higher differences will create high speed variations during the opening and closing movement;
- if the column dimensions or the position of the hinge (dimension D) do not make it possible to reach the required A dimension, a niche must be carved in the column as shown in Fig. 5;

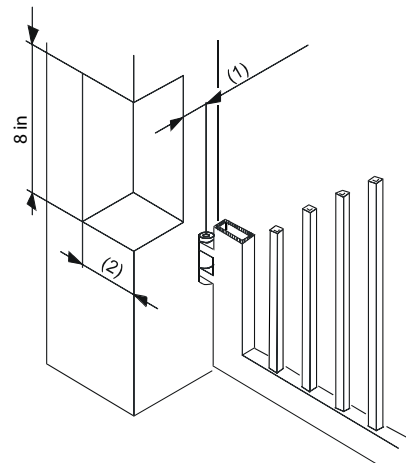

- (1) Length of dimension "A" - 2 in.
- (2) Length of dimension "B" + 4 in.

Fig. 5

2.4. INSTALLATION OF THE OPERATOR

Installing the model 422 operator consists of the following steps:

1. Attach the rear mounting bracket
2. Attach the operator to the rear mounting bracket
3. Attach the front mounting bracket to the operator
4. Attach the operator to the gate
5. Adjust the hydraulic pressures for the operator

Attach the rear mounting bracket

Attach the rear mounting bracket according to the dimensions in Figure 4a or 4b.

WARNING! You must achieve the A and B dimensions as specified in Figure 4a. Modification of the rear bracket may be necessary to achieve these dimensions (i.e. cutting or extending the bracket provided).

If there is a steel gate post, weld the rear bracket directly to it. If the gate post is made of any other material, attach the optional mounting plate, with lag bolts or anchors, and weld the bracket to it.

For an outward swing gate refer to Figure 4b.

Attach the mounting hardware

Place the operator so that the release lock faces up. Place the mounting fork in the operator's rear flange, secure with the long brass pin and selflocking nut.

Attach the fork assembly to the rear mounting bracket and secure with the short pint, washer, and nut.

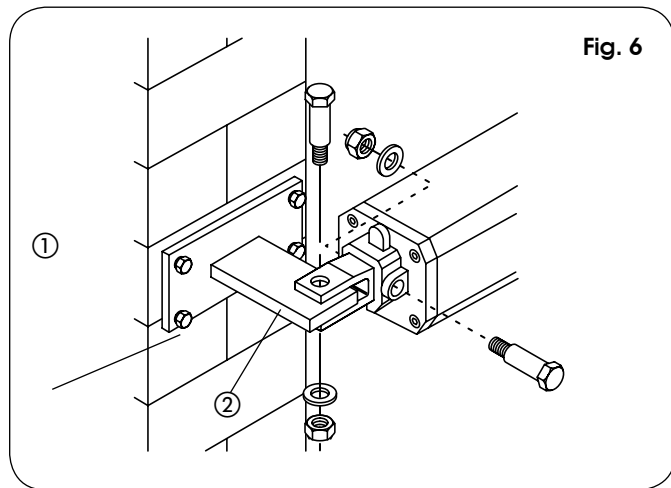

Attach the front mounting bracket to the operator

Release the operator as shown in Par. 3.

For inward swing, pull the piston completely out and push it back inward approximately 1/4" (6mm).

For outward swing, push the piston in completely and pull it back out approximately 1/4" (6mm).

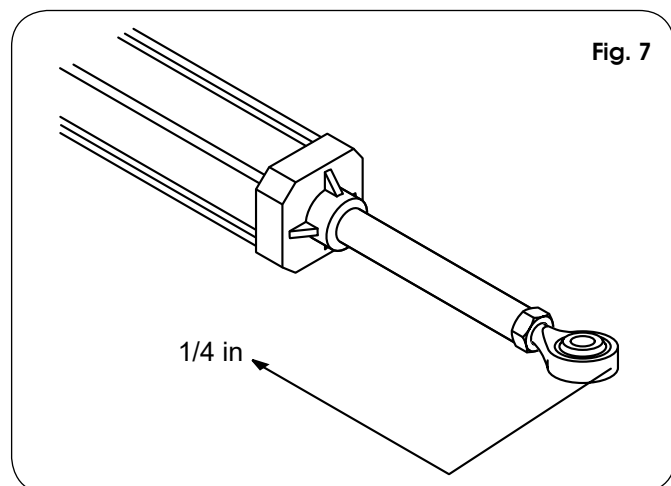

Push the front pin through the front mounting bracket then the piston rod to temporarily attach them together.

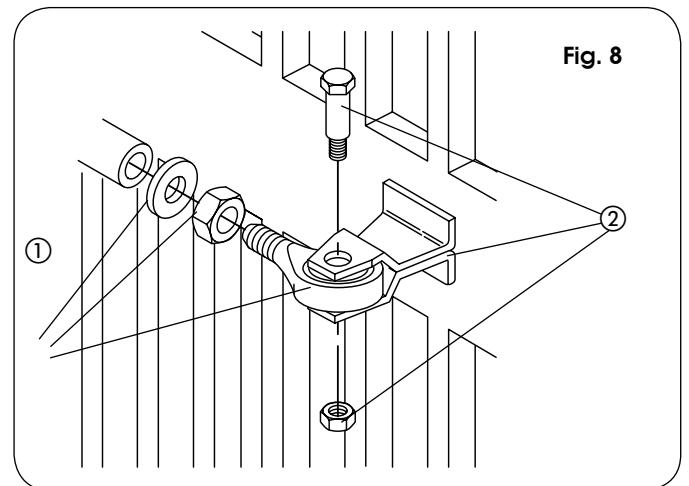

Make sure the operator is level and that the gate is against the closed positive stop.

Hold the front mounting bracket flush against the gate, mark the location of the front mounting bracket, remove the operator from the gate. Remove the front mounting bracket from the piston rod.

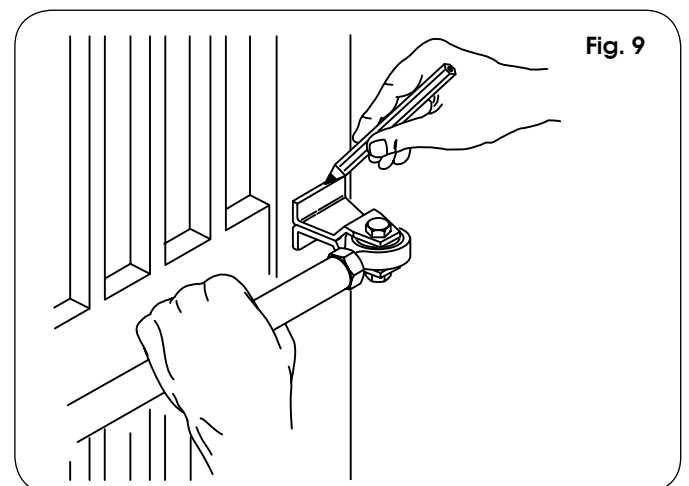

Spot weld the front bracket on the leaf, protecting the rod against any welding waste.

WARNING! Do Not Weld the front mounting bracket with the operator attached. Doing so will seriously damage the operator. Make sure the gate structure allows the bracket to be firmly fastened, otherwise create a solid support base.

Release the operator and manually check if the gate is free to open completely, stopping on the positive stops, and if leaf movement is good and without friction.

Complete the welding of the front bracket to the gate leaf.

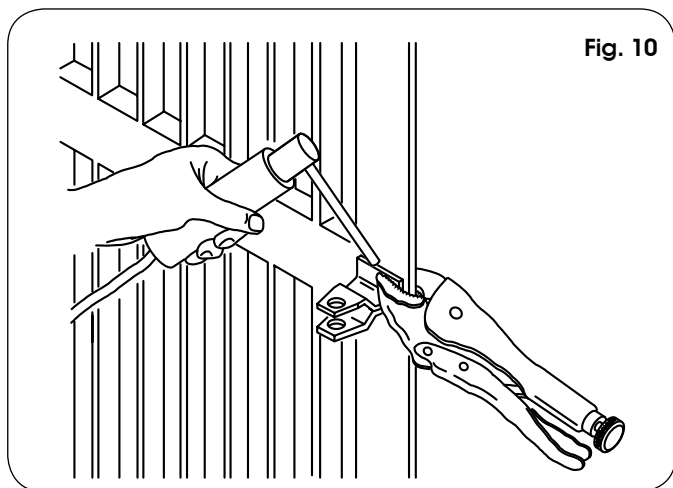

Attach the operator to the gate

Re-attach the operator to the mounting brackets. Once the operator is mounted and level, remove the vent screw from the bottom of the valve body (Fig. 11, ref. 1). Use a 3mm hex wrench.

WARNING! Failure to remove the vent screw may result in erratic operation of the operator or blown seals.

Slowly move the gate open and close, the piston should not bottom out in either direction. Be sure that the gate reaches the positive stop before the piston bottoms out.

Attach the connector with the cable and secure it with the supplied screws (Fig 12). Make sure the strain relief is tight on the connector.

Slip the cover over the operator. The slit in the cover should face the gate, and the cover should be placed firmly over the rear of the operator cover (Fig. 13, ref. 1).

Fix the end cap (3) to the cover using the black plastic screws (4).

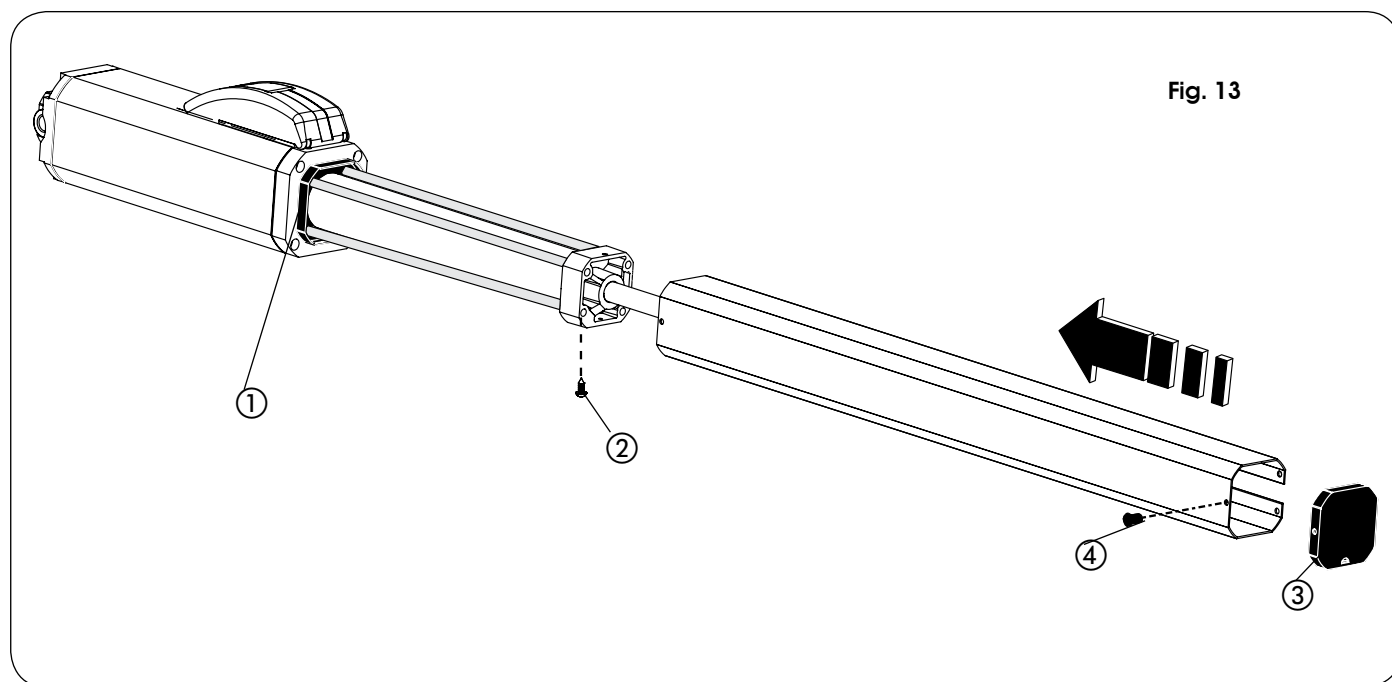
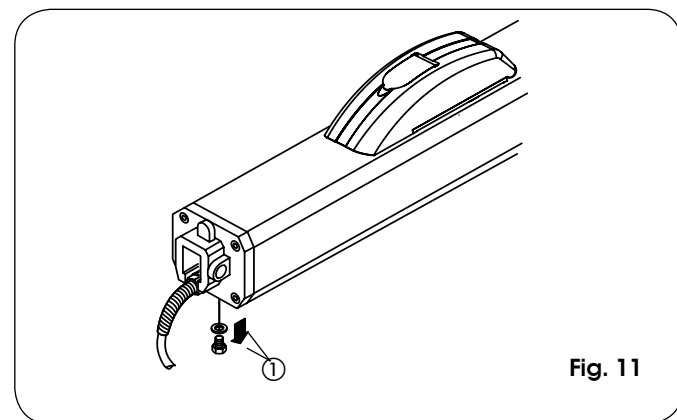
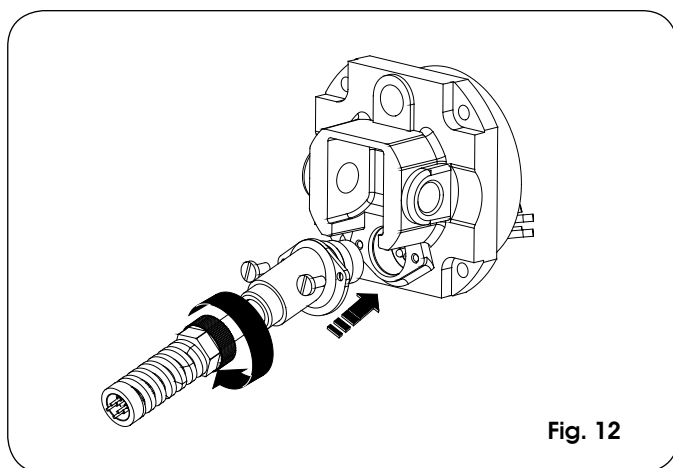

2.5. BY-PASS VALVES ADJUSTMENT

The 422 operator has an anti-crushing safety device which limits the operator's force if an obstacle is encountered while the gate is moving.

To adjust the intervention threshold of the anti-crushing system, turn the By-Pass screws, that are accessible under the manual release cover.

Lift the protective plug (Fig. 14, ref. 1) and insert the supplied key (Fig. 14, ref. 2). Turn it 90° clockwise to unlock the cover.

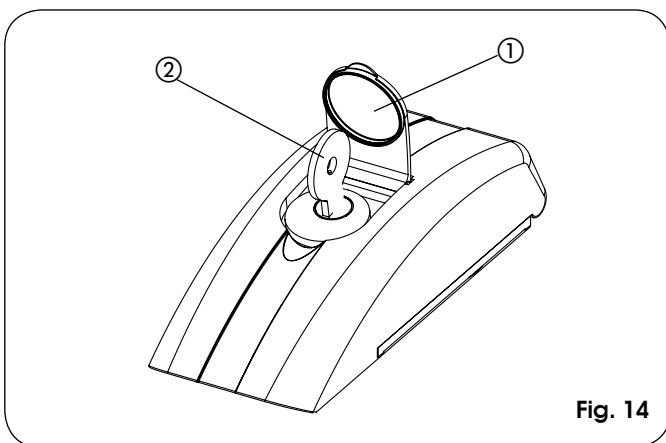

Fig. 14

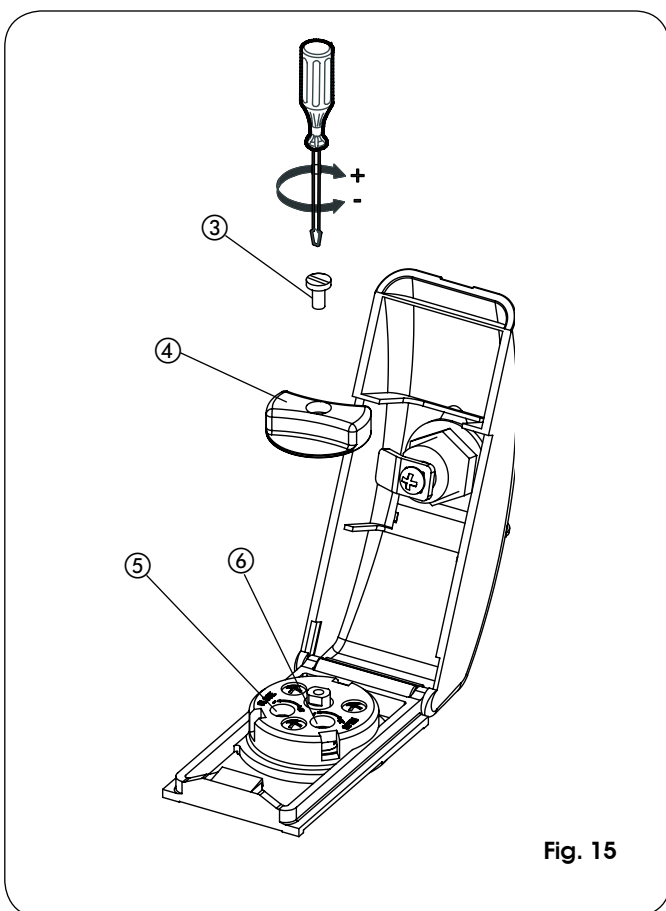

Fig. 15

Lift up the cover (Fig. 15)

Unscrew the screw that secures the knob (Fig. 15, ref. 3), and pull out the knob (Fig. 14, ref. 4).

Turn the pressure adjustment screws (By-Pass) (Fig. 15, ref. 5 and 6) on the operator.

OPEN screw (green) : gate opening direction.

CLOSE screw (red) : gate closing direction.

(the opposite applies in case of outwards opening)

To reduce pressure, turn the screws counterclockwise.

To increase pressure, turn the screws clockwise.

When the adjustment is complete, re-position the knob (Fig. 15, ref. 4) and tight the screw (Fig. 15, ref. c).

Close the cover and lock it by turning the key counterclockwise.

3. MANUAL OPERATION

If the gate has to be moved manually due to a power outage or other failures, use the release device as follows:

- Lift the protective plug (Fig. 16, ref. 1) and insert the supplied key (Fig. 16, ref.2). Turn it 90° clockwise to unlock the cover.

- Lift up the cover (Fig. 16 ref. 3).

- Turn the release knob counterclockwise for about two turns (Fig. 16, ref. 4).

- Open or close the leaf manually.

Restoring Normal Operation Mode

- To re-lock the operator, turn the release knob clockwise until it stops (Fig. 16, ref. 4).

- Close the cover and turn the key 90° counterclockwise (Fig. 16, ref. 2).

- Finally, remove the key and close the protective plug (Fig. 16, ref. 1).

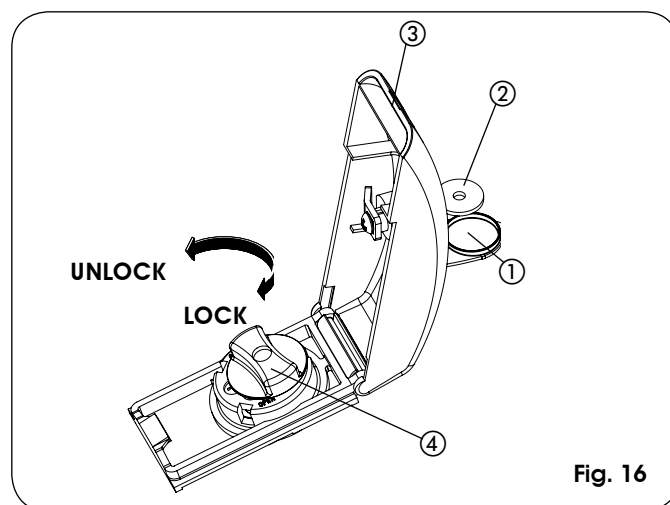

Fig. 16

4. MAINTENANCE

Run a functional check of the system at least every 6 months. Pay special attention to the efficiency of the safety and release devices (Including the thrust force of the operator), and the perfect operation of the gate hinges.

Checking oil level:

Periodically check the oil level inside the tank

- Cut power to the system.
- Position the operator vertically, with the rear flange high up.
- Remove the oil filling plug.
- Insert a screwdriver until it comes into contact with the electric motor as shown in Fig. 18.
- Remove the screwdriver and check oil level as shown in Fig. 18.



USE ONLY FAAC HP FLUID OIL

Periodically check the correct the adjustment of the anti-crushing safety device (BY-PASS) and the efficiency of the release system to allow manual operation.

The safety devices installed on the system must be checked every 6 months.

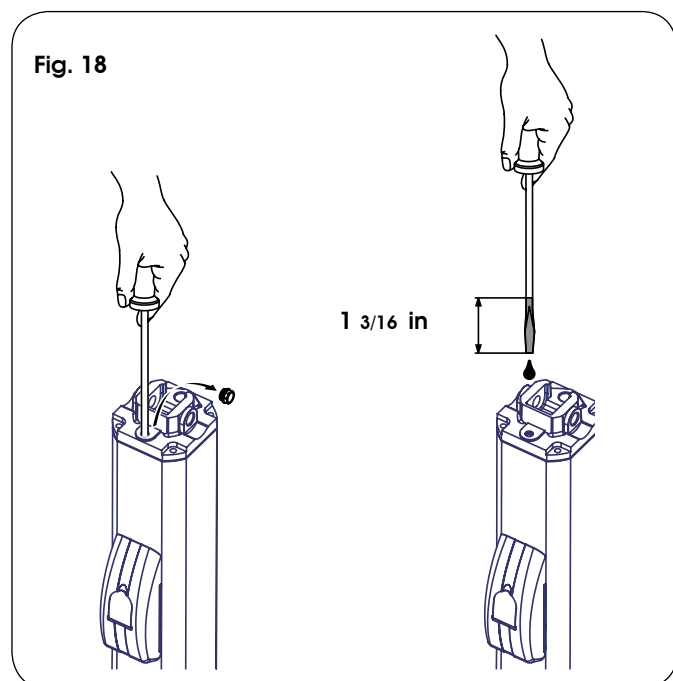

REPAIRS

For any repairs, contact FAAC's authorised Repair Centers.

5. SPARE PARTS

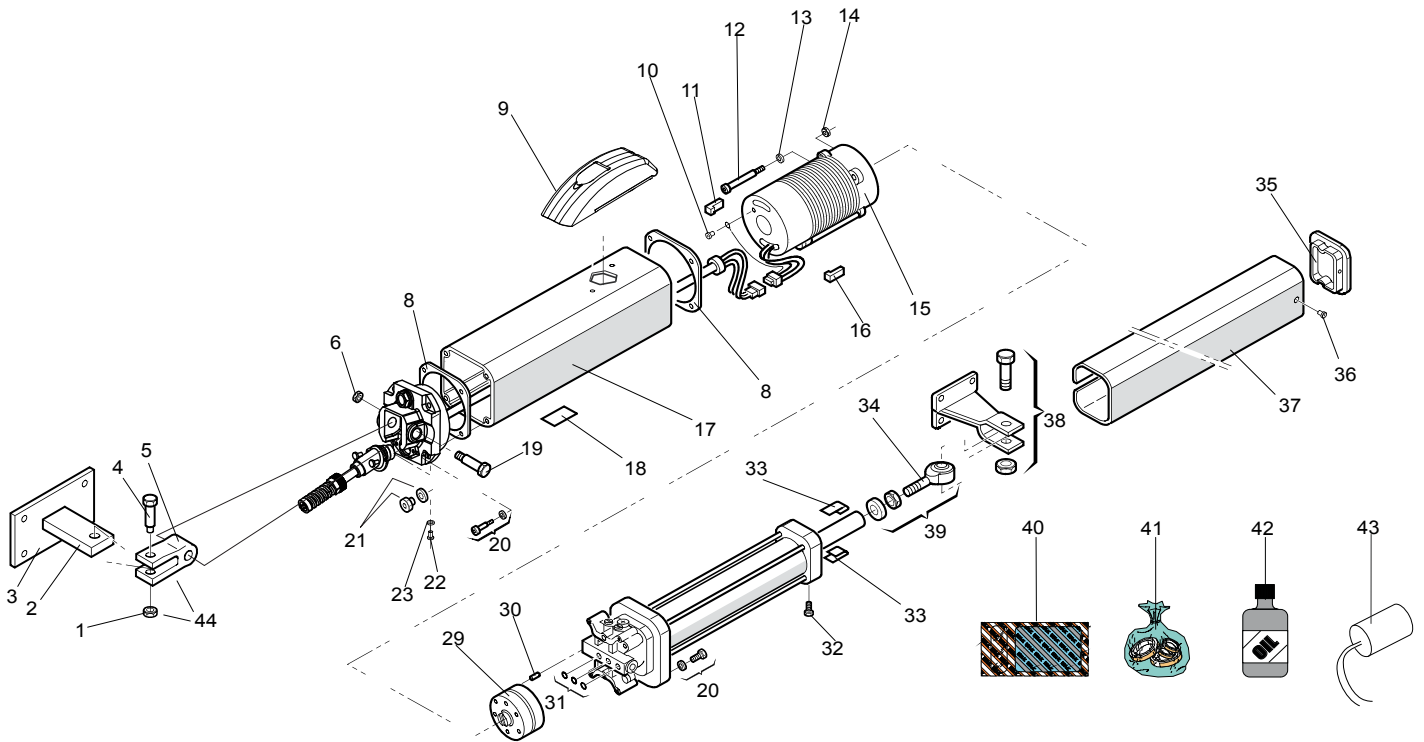

Part	Part Number	Description
01	2036	Nut 8mm
02	7220015	Rear braket motor
03	7284005	Rear bracket Plate
04	7182075	Short pin
05	7228015	Rear fork
06	2037	Self Locking Nut
08	70991015	Gasket (D80)
09	4185045.5	Locking Cap Kit
10	701803	Self Threading Screw 4x10mm
11	7119475	Vibration Dampener
12	2365	Motor Bolt 4 x 50 mm
13	2366	Lock Washer
14	702003	Hex Nut (4 mm)
15	77000425	Motor 115V 1400 rpm
16	7119485	Vibration Dampener
17	7161815	Operator Body
18	7320065	Vent Screw Label
19	7182175	Long pin
20	701829	Screw Torx 5x20 mm

Part	Part Number	Description
21	7110015	Oil Cap
22	2275	Vent Screw 4 x 20 mm
23	7094065	Copper washer
29	3204425	Cast iron pump 1 lt
30	706152	Pump Pin
31	7090010015	O-Ring 4.48x178 mm
32	701405	Self Threading Screw 3.5 x 9.5
33	7260285	Cover Antivibration Spacer
34	7073035	Swivel Joint
35	7271545	Protective Cover End Cap
36	711402	Protective Cover Plug
37	7272125	Protective Cover
38	7220515	Front Mounting Bracket
39	4900605	Swivel Joint Kit
40	3900995	Skin Pack
41	2172.1	Seal Kit
42	714019 Qt.1	FAAC Oil: 1 qt.
42	7140251 Qt.1	FAAC Arctic Oil: 1 qt.
43	2705	Capacitor for 115VAC Motor
44	7228015.1	Aluminum Fork Kit

NOTE:

220 VAC 8 uF Motor
8uF Capacitor for 220 VAC Motor

p/n 7700205
p/n 2707

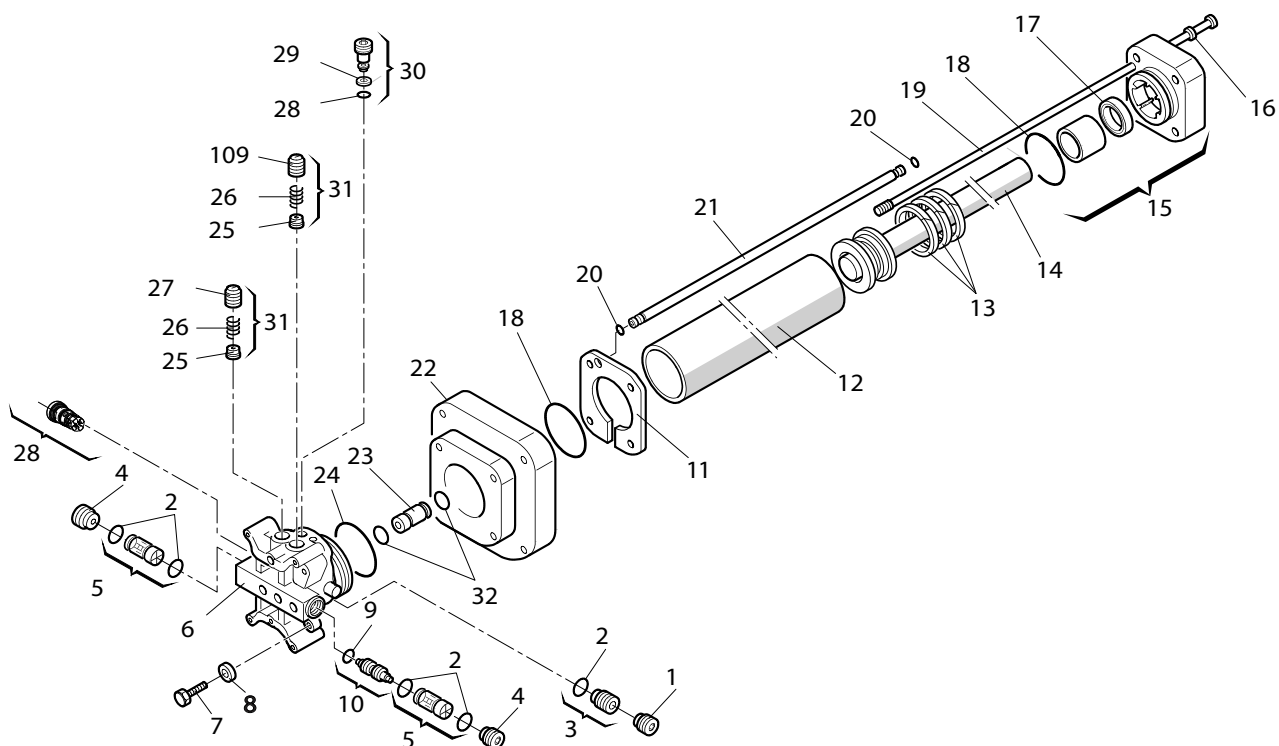

Part	Part Number	Description
01	7049135	Valox valve retaining ring nut
02	7090050015	O-Ring 10.82 x 1.78mm
03	4404065	Inlet Valve
04	7049005	Brass Valve Retainer
05	4404085	Stop valve in zamack
06	4994655	Distribution flange CBAC
07	701020	Screw 5 x 40 mm
08	703007	Washer
09	7090300015	O-Ring 7.66 x 1.78mm
10	4180285	Shuttle Piston with OR
11	7271555	Protective Cover Guide
12	7366065	Cylinder
13	7095035	Piston Rod Packing
14	4350085	Piston assembly
15	4994165	Front flange
16	703204	Star Washer

Part	Part Number	Description
17	63000655	Front Flange Seal (internal)
18	7090360025	O-ring 40.95 x 2.62
19	7230225	Tie Rod (Cylinder)
20	7090635	O-Ring 5 x1.5 mm
21	7361315	Retract tube alum.
22	499449	Mid Flange
23	7361035	Retract Tube Small
24	7090360025	O-ring 40.95 x 2.62
25	7310315	By-pass Spacer
26	7210025	By-pass Spring
27	4180415	By-pass Cap
28	4404095	Inlet Valve (Bi-directional)
29	7043055	Ring Spacer
30	4180195	Manual Release
031	4180415	By-pass Assembly
032	7090280015	O-Ring 5.28 x 1.78 mm

455D CONTROL BOARD

1. General Description

The 455 D control board is used to operate the FAAC High Voltage swing gate operators. It has several operating logics built in, programmable with the help of a display and push-buttons. The board allows connection of various accessories including monitored photocell for compliance with the UL325 standard Ed: 6.

The 455 D control board should be installed in an enclosure that is conveniently located as close as possible to the gate operator. All electrical connections from the control board to the operator must be made in a weatherproof junction box.

2. Technical Specifications

Input Voltage	115 V~ ± 10% or 230 V~ +6% -10% 50/60 Hz
Input Power	10 W
Motor Max. Load	800 W
Accessories Max. Load	0,5 A
Electric Lock Max. Load	15 VA
Ambient Operating Temperature Range	-4°F to +131°F
Protection Fuses	5A (230V version) 10A (115V Version) 800 mA (accessory)

3. Features

Function Logics:

Semi-automatic / Automatic / Safety Devices / "Stepped" Semi-automatic / "Stepped" Automatic / "Stepped" Safety Devices / Semi-automatic B / Dead-man C

Opening/Closing Time:

Programmable (from 0 to 120 s)

Pause Time:

Programmable (from 0 to 4 min.)

Closing Leaf Delay:

Programmable (from 0 to 4 min.)

Opening Leaf Delay:

2 s (can be excluded)

Thrust Force:

Adjustable on 50 levels for each motor

Terminal Board Inputs:

Open / Open Free Leaf / Stop / Limit-switch / Opening Safety Devices / Closing Safety Devices / Power Supply + Earth.

Terminal Board Outputs:

Flashing Lamp / Motors / 24 VDC Accessories Power Supply / 24 VDC Indicator-Light / Fail Safe / 12 VAC Electric Lock Power Supply

Programmable Functions:

Logic / Pause Time / Thrust Force / Torque at Initial Thrust / Opening and Closing Leaf Delay / Reversing Stroke / Over-Pushing Stroke / Indicator-Light / Pre-Flashing / Electric Lock / Fail Safe / Safety Devices Logic / Assistance Request / Detection Time of Obstacle or Contact Point

Learning Function:

Simple or complete work time learning, with or without Limit-switches

4. Layout and Components

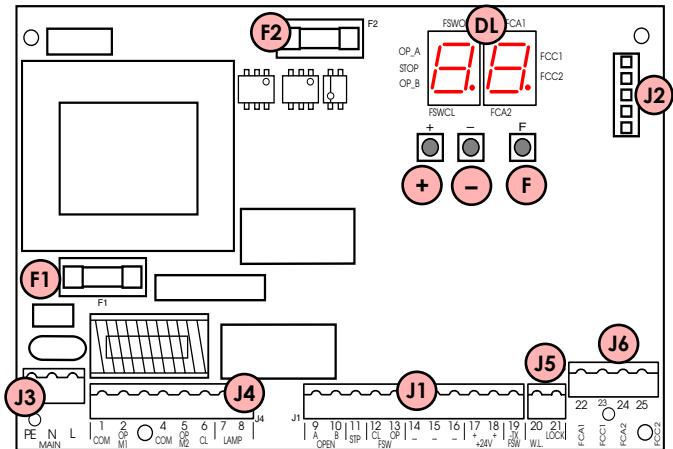

DL STATUS AND PROGRAMMING DISPLAY

J1 LOW VOLTAGE TERMINAL BLOCK

J2 CONNECTOR FOR RADIO RECEIVER

J3 AC POWER SUPPLY TERMINAL BLOCK

J4 MOTORS AND WARNING LAMP TERMINAL BLOCK

J5 INDICATOR-LIGHT AND ELECTRIC LOCK TERMINAL BLOCK

J6 LIMIT-SWITCH TERMINAL BLOCK

F1 MOTORS AND TRANSFORMER PRIMARY WINDING FUSE (F 5A - 230V) (F 10A - 115V)

F2 LOW VOLTAGE AND ACCESSORIES FUSE (T 800mA)

F "F" PROGRAMMING PUSH-BUTTON

- "-" PROGRAMMING PUSH-BUTTON

+ "+" PROGRAMMING PUSH-BUTTON

Connector J2 - Rapid Connection to RP Receivers

The 5 pin J2 connector allows to plug in the FAAC RP radio receivers

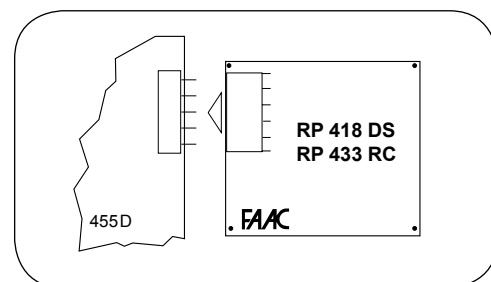

Terminal Block J3 - Power Supply

PE: Earth Connection / Ground

N: AC V~ power supply (Neutral)

L: AC V~ power supply (Line)



The installer is responsible for grounding the operator system, for providing the main power breaker switch, and for making sure that the entire gate system meets all applicable electrical codes.

5. Electric Connections

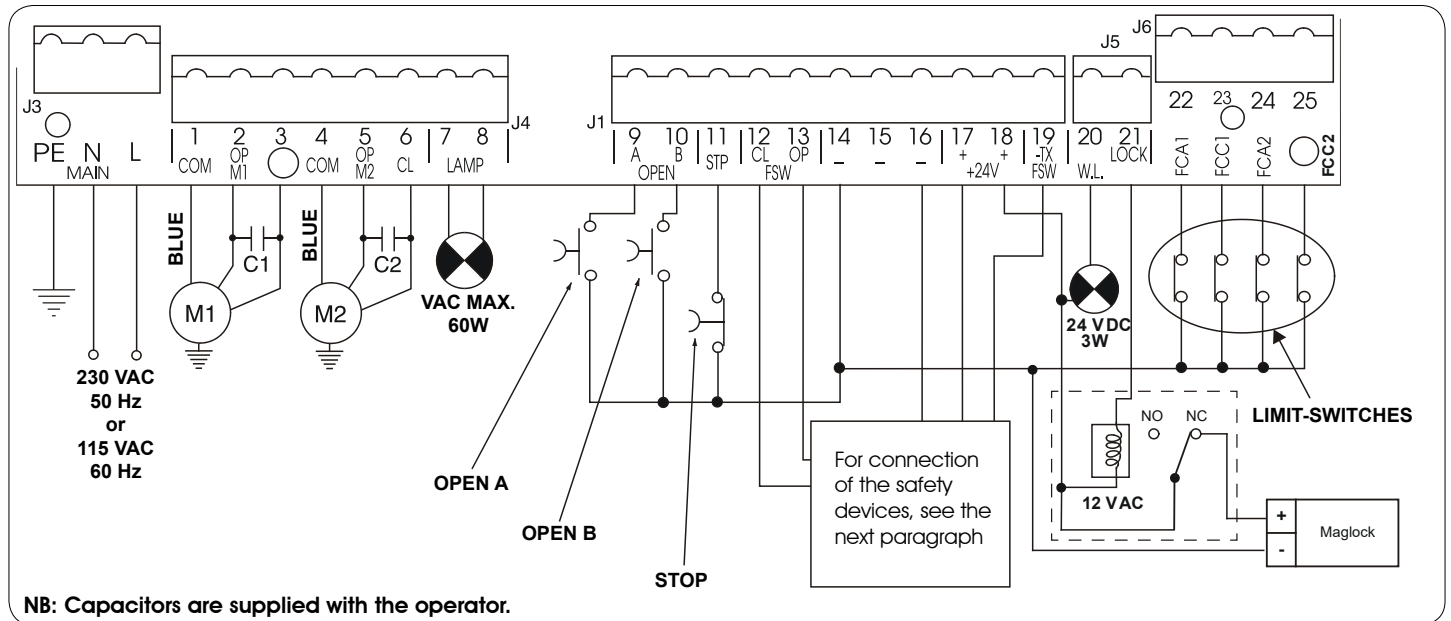

Terminal Block J4 - Motors and Warning Lamp

M1: COM / OP / CL: Connection to Motor 1
Must be used for single-leaf configuration

M2: COM / OP / CL: Connection to Motor 2
Cannot be used in single-leaf configurations

LAMP: Warning lamp output (AC V ~)

Terminal Block J1 - Accessories

OPEN A - "Total Opening" Command (N.O.):

Any pulse generator (push-button, detector, etc.) which, by closing a contact, commands opening and/or closing of both gate leaves. To install several full opening pulse generators, connect the N.O. contacts in parallel.

OPEN B - "Partial Opening" Command (N.O.) / Closing:

Any pulse generator (push-button, detector, etc.) which, by closing a contact, commands opening and/or closing of the leaf driven by motor M1. In the B and C logics, it always commands closing of both leaves. To install several partial opening pulse generators, connect the N.O. contacts in parallel. See logic chart for exact operation.

STP - STOP Contact (N.C.):

Any device (e.g. a push-button) which, by opening a contact, is able to stop gate movement. To install several STOP devices, connect the N.C. contacts in series.

NB: If STOP devices are not used, connect a jumper between the STP terminals and -.

CL FSW - Closing Safety Contact (N.C.):

The closing safety input is used to protect the leaf movement area during closing. While closing, an activation of the the safety device connected to this input will reverse the movement of the gate leaves. This input is inactive during the opening cycle. **To be compliant with the UL325 standard at least one monitored safety device must be connected to this input.** See the next paragraph on how to connect a monitored device. If this input is active when the gate is open it will prevent the leaf closing movement.

OP FSW - Opening safety devices contact (N.C.):

The opening safety input is used to protect the leaf movement area during opening. While opening, an activation of the the safety device connected to this input will reverse the movement of the gate leaves. This input is inactive during the closing cycle. To be compliant with the UL325 standard if this input is used to protect an entrapment zone at least one monitored safety device must be connected to it. See the next paragraph on how to connect a monitored device. If this input is active when the gate is closed it will prevent the leaf opening movement.

= - Negative for power supply to accessories

± - 24 VDC - Positive for power supply to accessories

Important: Accessories max. load is 500 mA. To calculate current draw, refer to the instructions for individual accessories.

-TX FSW - Negative Power to photocell transmitters.

This terminal is used for the photocells monitoring feature. Compliance with the UL325 standard requires connecting the transmitter photocell negative power to this input and activating the FAIL SAFE function (see *Advanced Programming*). This will allow the 455 D board to check the correct operation of the safety photocells before each opening or closing cycle.

Terminal Block J5 - Indicator-Light and Electric Lock

W.L. - Power supply to indicator-light

Connect a 24 VDC - 3 W max. indicator-light, if necessary, between this terminal and the +24V supply. To avoid compromising correct operation of the system, do not exceed the indicated power.

LOCK - Power supply to electric lock

If necessary, connect a 12 Vac electric strike lock between this terminal and the +24V power supply. Or connect a 12 Vac relay and a Maglock following the schematic above.

Terminal Block J6 - Limit-Switches

These inputs are dedicated to the connection of opening and closing limit switches

6. Connection of Safety devices

Entrapment protection

To comply with the UL325 standard for gate operators every entrapment zone, as defined in ASTM F2200, must be protected by two independent entrapment protection devices. One of the devices is inherent in the FAAC operators or the control board design, the other can be external, like a photocell or an edge sensor.

See this picture for the photocells positioning:

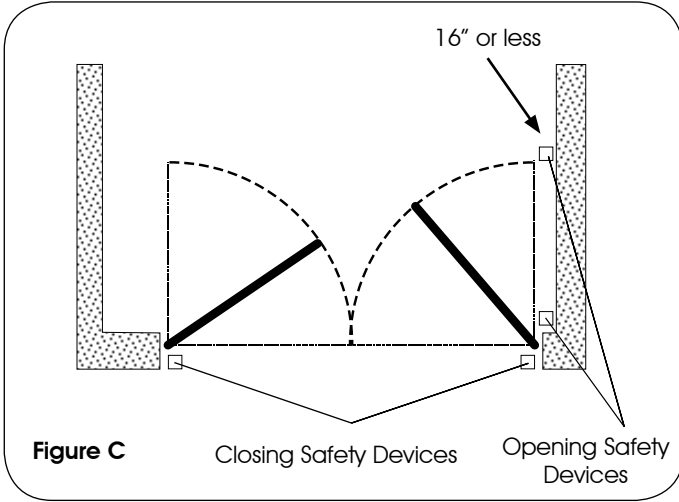

Opening Safety Devices:

Are active only during the gate opening movement, and are suitable for protecting the area between the opening leaves and fixed obstacles (walls, etc) against the risk of entrapment

Closing Safety Devices:

Are active only during the gate closing movement, and are suitable for protecting the closing area against the risk of entrapment.

Monitored Devices:

Additionally the UL325 standard requires that every external entrapment protection device must be monitored for presence and correct operation. To comply with this requirement the photocells must be wired as shown:

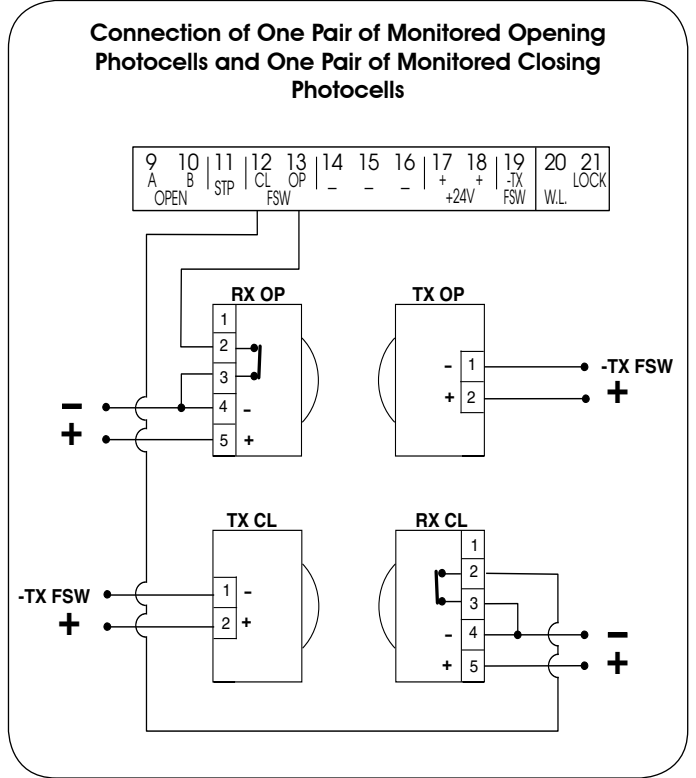

Once the photocells are wired the Fail Safe mode of the 455D control board must be enabled. To enable it enter in advanced programming by pressing and holding "F" and then press "+", scroll to the "FS" parameter and select "Active".

For more details please refer to the advanced programming paragraph.

ADVANCED PROGRAMMING (F) + (+)		
Display	Function	Default
FS	<p>FAIL SAFE:</p> <p>If this function is activated, it enables a function test of the photocells before any gate movement. If the test fails (photocells not serviceable), the gate does not start the movement.</p> <p>4 = Active 70 = Disabled</p>	70

Only one monitored photocell can be connected to the Closing or Opening safety inputs. More than one photocell or other device can be connected to the safety inputs, but they will not be monitored.

Other devices connected to the safety inputs must have normally closed contacts and wired in series with the main monitored sensor.

See the following example of one closing safety monitored photocell and one non monitored one.

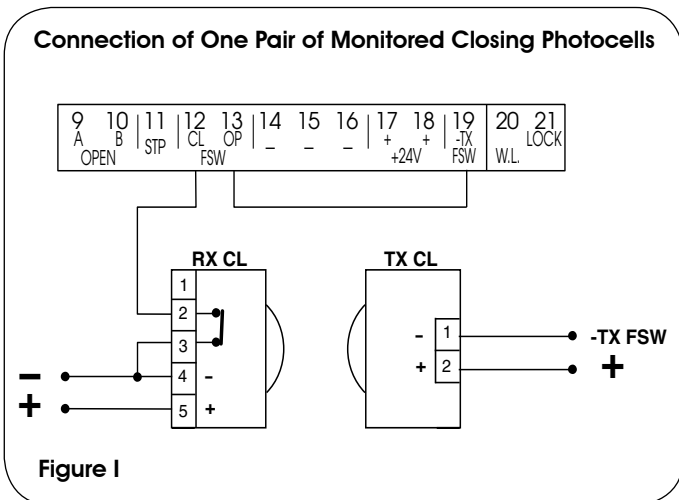

Connection of Two Pairs of Closing Photocells, One Monitored and One non Monitored

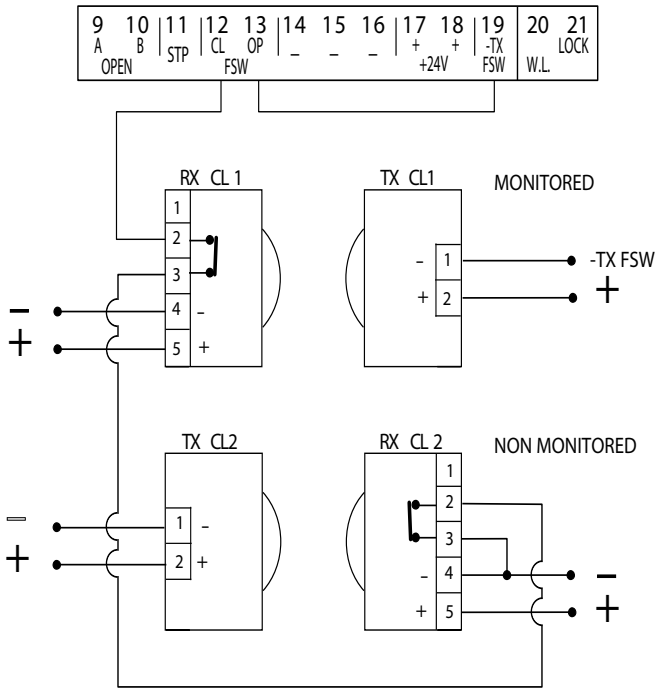

Connection of One Pair of Closing Photocells (monitored), One Pair of Opening Photocells (monitored) and One pair of Opening/Closing Photocells (non monitored)

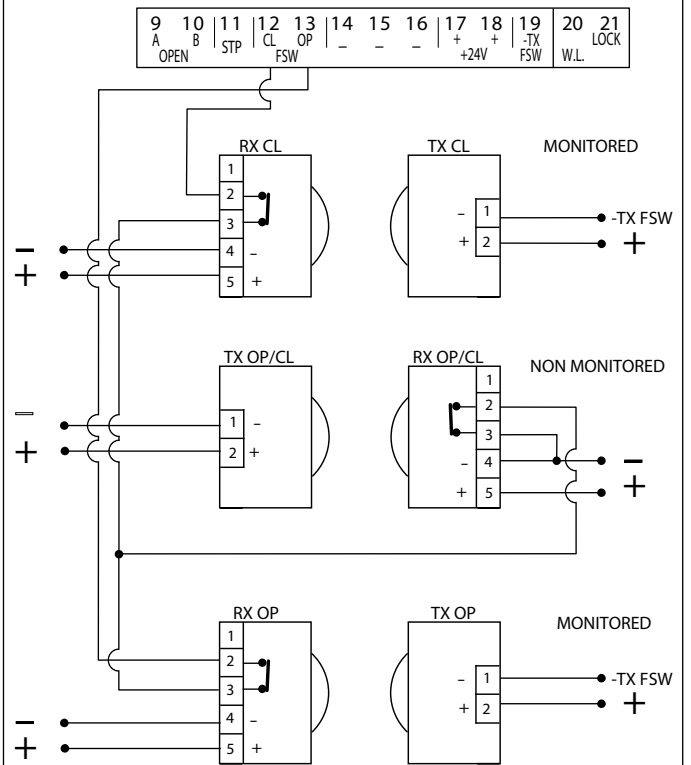

Opening/Closing Safety Devices:

They operate during the gate opening and closing movements and are suitable to protect the opening and closing areas against the risk of impact. Typically these photocells work in combination with other monitored photocell protecting closing or opening entrapment zones. In that case they can't be monitored so they can only protect against potential impact on vehicles.

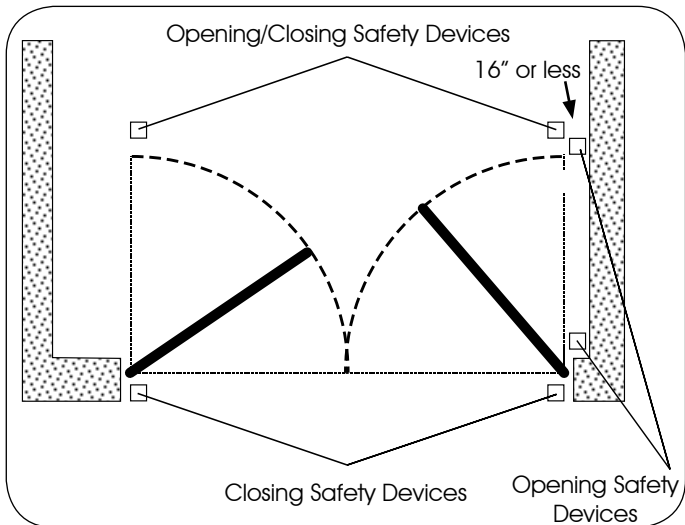

7. Operating Logics

This is a brief description of the main operating logics of the system. For a complete description please refer to Table 3

- A (automatic): The gate opens on command and automatically closes after a pause phase. A second command while opening is ignored; a second command during the pause phase interrupts the pause time; a second command during closing reopens the gate. A maintained open command will hold the gate open.
- S (security): The security mode is like A logic except that a second command during opening immediately closes the gate. A maintained open command will not hold the gate open.
- E (semi-automatic): This mode requires a command to open and a command to close. A second command during opening stops the gate. A second command during closing reopens the gate.
- EP (semi-automatic, step by step): This mode requires a command to open and a command to close. A second command during opening or closing causes the gate to stop. A third command then reverses the previous motion of the gate.
- B (manned, pulsed): This mode is designed for guard station use and requires a three button switch (pulsed) to open, close, and stop the gate.
- C (manned and constant): This mode requires constant pressure switches. One to open and one to close. No pressure on a switch stops the gate.

8. Programming

To program the 455D Control Board, you have to access "PROGRAMMING" mode. Programming is split into two parts: BASIC and ADVANCED.

Basic Programming:

To access BASIC PROGRAMMING, press key **F**:

- Press and hold **F**, the unit will display the name of the first function / parameter.
- When you release the key, the unit will display the parameter's current value.
- Value can be modified with keys + and - .
- Press and hold **F** again, the unit will display the name of the next function / parameter.
- When you reach the last function, press **F** to exit the program, the display resumes monitoring input status.
- IMPORTANT: Make sure to exit programming mode otherwise the changes will not be saved.

The following table displays the sequence of functions accessible in BASIC PROGRAMMING:

BASIC PROGRAMMING <small>press F</small>		
Display	Function	Default
LO	OPERATING LOGICS (see tab. 3/a - h): E = Semi-automatic A = Automatic S = "Safety" Automatic EP = "Stepped" Semi-automatic AP = "Stepped" Automatic SP = "Safety Stepped" Automatic b = "B" Semi-automatic C = Dead-man	E
PA	PAUSE TIME: This has effect only when automatic logic is selected. Adjustable from 0 to 59 secs. in one-second increments. Subsequently, display changes to minutes and tenths of seconds (separated by a decimal point), time is adjusted in 10-second increments, up to 4.1 minutes max. Thus, if the unit displays 2.5, Pause Time is 2 mins. and 50 secs.	0
F1	LEAF 1 FORCE: Adjusts thrust of Motor 1. 1 = minimum force 50 = maximum force (hydraulic)	25
F2	LEAF 2 FORCE: Adjusts thrust of Motor 2. 1 = minimum force 50 = maximum force (hydraulic)	25
cd	LEAF 1 CLOSING DELAY: Delays closing start of leaf 1 with respect to leaf 2. Adjustable from 0 to 4.1 minutes (see Pause Time).	0
EL	TIME LEARNING (see Section F.3.): Enables the selection between "simple" learning and "complete" (manual choice of deceleration and stop points) learning. Simple Learning: (+) ≈ 1 s. Complete Learning: (+) > 3 s.	
In	Exit from programming and return to inputs status monitoring.	

For hydraulic operators, set force to the maximum level.

Advanced Programming:

To access **ADVANCED PROGRAMMING**, press and hold key **F** and then press key **+**:

- Release key **+**, the unit displays the name of the first function.
- Release key **F**, modify the value of the function with keys **+** and **-**.
- Press and hold key **F**, the unit displays the name of the next function, and if you release it, the value that can be modified with keys **+** and **-**.
- When you reach the last function, press **F** to exit the program, the unit resumes monitoring input status.

The following table shows the sequence of functions accessible in **ADVANCED PROGRAMMING**:

ADVANCED PROGRAMMING (F) + (+)		
Display	Function	Default
60	MAXIMUM TORQUE AT INITIAL THRUST: The motors operate at maximum torque (ignoring the torque setting) at start of movement. Useful for heavy leaves. 4 = Active n0 = Disabled	n0
c5	LAST STROKE AT CLOSING: The motors are activated at full speed for 1 second to facilitate locking of the electric lock. 4 = Active n0 = Disabled	n0
r5	REVERSING STROKE: Before opening, while the gate is closed, the motors thrust to close for 2 seconds thus facilitating release of the electric lock. 4 = Active n0 = Disabled	n0
od	LEAF 2 OPENING DELAY (2 s): Enables delayed start (at opening) of leaf 2, avoiding interference between leaves. 4 = Active n0 = Disabled	n0
f5	FAIL SAFE: If this function is activated, it enables a function test of the photocells before any gate movement. If the test fails (photocells not serviceable), the gate does not start the movement. 4 = Active n0 = Disabled	n0
pf	PRE-FLASHING (5 s): Activates the flashing lamp for 5 seconds before start of movement. 4 = Active n0 = Disabled	n0
el	ELECTRIC LOCK ON LEAF 2: For using the electric lock on leaf 2 instead of on leaf 1. 4 = Active n0 = Disabled	n0

Display	Function	Default
sp	INDICATOR-LIGHT: If 0 is selected, the output functions as a standard indicator-light (lighted at opening and pause, flashing at closing, and off when gate is closed). Different figures correspond to the extra time compared to normal work time (opening or closing) when the output can be used - via a relay - to power a courtesy light. Time can be adjusted from 1 to 59 sec. in 1 sec. steps, and from 10 to 41 min. in 10 sec. steps. 0 = Standard indicator-light from 1 to 41 = Timed output	0
ph	CLOSING PHOTOCELLS REVERSE AT RELEASE: Enable this function if you want the closing photocells to stop movement and reverse at release. Default setting is immediate reverse. 4 = Active n0 = Disabled	n0
ad	A.D.M.A.P FUNCTION: When enabled, the safety devices operate in compliance with French standard NFP 25/362. 4 = Active n0 = Disabled	n0
as	ASSISTANCE REQUEST (combined with next function): If activated, at the end of countdown (settable with the next function i.e. "Cycle programming") it affects 8 s of pre-flashing at every Open pulse (job request). Can be useful for setting scheduled maintenance jobs. 4 = Active n0 = Disabled	n0
nc	CYCLE PROGRAMMING: For setting countdown of system operation cycles. Settable (in thousands) from 0 to 99 thousand cycles. The displayed value is updated as cycles proceed. This function can be used to check use of the board or to exploit the "Assistance request".	0
ec	EXTRA WORK TIME: If reversing occurs, and if the leaf does not reach its end contact point, you can activate this function to increase work time. 4 = Active n0 = Disabled	n0
in	Exit from programming and return to inputs status monitoring.	

NOTE: Parameter modifications take effect immediately. Exit out of programming to save changes. If the equipment is powered down before returning to normal status monitoring, any unsaved modifications will be lost.

To restore programming defaults, press and hold the three buttons **+**, **-**, **F** simultaneously for 5 seconds.

9. Start-up

LED Indicators:

The board has a two-digit display. When not in "PROGRAMMING" mode, this display is used to indicate the status of inputs. The figure below shows how the LED segments are mapped to the corresponding the inputs.

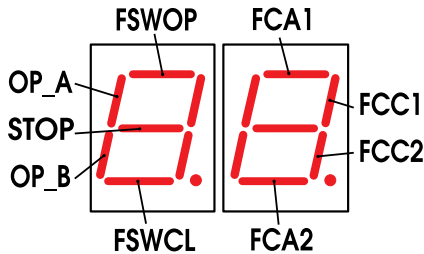

The table below shows the status of the LEDs in relation to the status of the inputs.

Note the following: **LED ON** = closed contact
LED OFF = open contact

Operation of the Status Signaling LEDs

LEDs	ON	OFF
OP_A	Command activated	Command inactive
OP_B	Command activated	Command inactive
STOP	Command inactive	Command activated
FSWCL	Safety devices clear	Safety devices triggered
FSWOP	Safety devices clear	Safety devices triggered
FCA1 (if used)	Limit switch free	Limit switch triggered
FCC1 (if used)	Limit switch free	Limit switch triggered
FCC2 (if used)	Limit switch free	Limit switch triggered
FCA2 (if used)	Limit switch free	Limit switch triggered

The status of the LEDs while the gate is closed at rest are shown in bold.

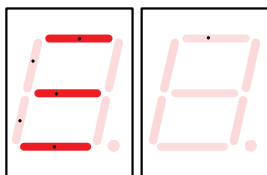

This is the normal status of the display with all the safety inputs clear and no activation signal present

Rotation direction and force check:

1. Program the functions of the 455 D control board according to need, as previously shown.
2. Cut power to the electronic control equipment.
3. Release the operators and manually move the gate to the mid-point of the opening angle.
4. Re-lock the operators.
5. Restore power.
6. Send an opening command on the OPEN A input and verify that the gate leaves start moving towards the open position

Note: If the first OPEN A pulse starts a closing movement, cut power and reverse the phases of the electric motor (red and black wires) on the 455 D control board.

7. Check force setting of the motors, modify if necessary.

Note: For hydraulic operators, like the 400, force should be programmed to maximum level (50)

8. Stop leaf movement with a STOP command.
9. Release the operators, close the leaves and re-lock the operators.

Opening/closing time is established by a time learning procedure which can be accomplished in "simple" or "complete" modes. The simple mode doesn't allow a slow down phase in the operator, while the complete mode does.

The slow down can be useful to reduce the mechanical stress on the gate, but it can create problems in high wind conditions.

10. Learning Operating Times

Make sure travel limit mechanical stops are present.



WARNING: During the learning procedure, safety devices are disabled! Avoid crossing the leaf movement area when this operation is carried out.

- SIMPLE LEARNING (Without Slow Down):

Check that the leaves are closed. Enter "BASIC PROGRAMMING," select the TIME LEARNING function and then press the + push-button for **1 second**. The display begins flashing and the leaves begin to open.

As soon as the leaves reach the opening contact point, provide an OPEN A pulse (with the key operated push-button or with the radio control) to stop the movement. The leaves stop and the display stops flashing.

Press push-button **F** to exit and save the programming. The procedure is complete and the gate is ready to operate.

- COMPLETE LEARNING (With Slow Down):

Check that the leaves are closed. Enter "BASIC PROGRAMMING," select the TIME LEARNING function and then press the + push-button for more than **3 seconds**. The display begins flashing and leaf 1 begins to open. The following functions can be performed by sending OPEN A pulses (by key push-button or radio control).

A total of 8 OPEN A commands required:

1. Slow down at opening of leaf 1
2. Leaf 1 stops at opening and leaf 2 begins its opening movement
3. Slow down at opening of leaf 2
4. Leaf 2 stops at opening and immediately begins its closing movement
5. Slow down at closing of leaf 2
6. Leaf 2 stops at closing and leaf 1 begins its closing movement
7. Slow down at closing of leaf 1
8. Leaf 1 stops at closing

When the display stops flashing, press push-button **F** to exit and save the programming. The procedure is complete and the gate is ready to operate.

Notes:

- *If you wish to eliminate deceleration in certain stages, wait for the leaf to reach its stop-limit and supply 2 consecutive Open pulses (by 1 second).*
- *If only one leaf is present, the entire sequence must nevertheless be completed. When the leaf has finished opening, supply 5 Open pulses until the leaf begins to close, and then resume normal operation.*

11. Final Tests

Once programming is complete and the proper operating times are stored in the board's memory perform a complete test the system. Verify that the operator(s) run properly and, most importantly, check that force is adequately adjusted and that safety devices are operating correctly.

After simple or complete learning the board will add 3 sec. to the programmed time so the operators will run against the stops.

Monitored safety test:

IMPORTANT: To make sure that the safety photocells protecting entrapment zones are monitored properly install a temporary jumper on the N.C. output of the photocell and give an OPEN A command. The gate must not move. otherwise check the wiring of the photocells and make sure that FAIL SAFE is enabled in Advanced Programming

12. Operating Modes Detailed Description

Tab. 3/a

PULSES						
Logic "E"	OPEN-A	OPEN-B	STOP	OPENING SAFETY DEVICES	CLOSING SAFETY DEVICES	OP/CL SAFETY DEVICE
GATE STATUS						
CLOSED	Opens the leaf	Opens single leaf		No effect (OPEN disabled)	No effect	No effect (OPEN disabled)
OPEN	Re-closes the leaf	Opens immediately (3)		No effect (if on part.opng. OPEN A disabled)	No effect (3) (OPEN disabled)	No effect (OPEN disabled)
CLOSING	Re-opens the leaf immediately		Stops operation	No effect (saves OPEN)	see paragraph 5.2.	Locks and, on release, reverses to open
OPENING	Stops operation (3)			Reverses to close	No effect	Locks and, on release, continues opening
LOCKED	Closes the leaf (with Closing Safety devices engaged, opens at the 2nd pulse) (3)		No effect (OPEN disabled)	No effect	No effect	No effect (OPEN disabled)

Tab. 3/b

PULSES						
Logic "A"	OPEN-A	OPEN-B	STOP	OPENING SAFETY DEVICES	CLOSING SAFETY DEVICES	OP/CL SAFETY DEVICE
GATE STATUS						
CLOSED	Opens the leaf and closes it after pause time (1)	Opens single leaf and closes after pause time (1)		No effect (OPEN disabled)	No effect	No effect (OPEN disabled)
OPEN on PAUSE	Reloads pause time (1)(3)			No effect (if on part.opng. OPEN A disabled)	Reloads pause time (1) (3)	Reloads pause time (1) (OPEN disabled)
CLOSING	Re-opens the leaf immediately (1)		Stops operation	No effect (saves OPEN)	see paragraph 5.2.	Locks and, on release, reverses to open
OPENING	No effect (1) (3)			Reverses to close	No effect	Locks and, on release, continues opening
LOCKED	Closes the leaf (3)		No effect (OPEN disabled)	No effect	No effect	No effect (OPEN disabled)

Tab. 3/c

PULSES						
Logic "S"	OPEN-A	OPEN-B	STOP	OPENING SAFETY DEVICES	CLOSING SAFETY DEVICES	OP/CL SAFETY DEVICE
GATE STATUS						
CLOSED	Opens the leaf and closes it after pause time	Opens single leaf and closes after pause time		No effect (OPEN disabled)	No effect	No effect (OPEN disabled)
OPEN on PAUSE	Re-closes the leaf immediately (3)			No effect (if on part.opng. OPEN A disabled)	On release, closes after 5" (OPEN disabled) (3)	On release, closes after 5" (OPEN disabled)
CLOSING	Re-opens the leaf immediately		Stops operation	No effect (saves OPEN)	see paragraph 5.2.	Locks and, on release, reverses to open
OPENING	Re-closes the leaf immediately (3)			Reverses to close	No effect (saves OPEN)	Locks and, on release, continues opening
LOCKED	Closes the leaf (3)		No effect (OPEN disabled)	No effect	No effect	No effect (OPEN disabled)

Tab. 3/d

PULSES						
Logic "EP"	OPEN-A	OPEN-B	STOP	OPENING SAFETY DEVICES	CLOSING SAFETY DEVICES	OP/CL SAFETY DEVICE
GATE STATUS						
CLOSED	Opens the leaf	Opens leaf for the partial opening time		No effect (OPEN disabled)	No effect	No effect (OPEN disabled)
OPEN	Re-closes the leaf immediately (3)			No effect (if on part.opng. OPEN A disabled)	No effect (OPEN disabled) (3)	No effect (OPEN disabled)
CLOSING	Stops operation		Stops operation	No effect (saves OPEN)	see paragraph 5.2.	Locks and, on release, reverses to open
OPENING	Stops operation (3)			see paragraph 5.2.	No effect	Locks and, on release, continues opening
LOCKED	Restarts movement in reverse direction (3) (always closes after a Stop)		No effect (OPEN disabled)	No effect (if it must open, it disables OPEN)	No effect (if it must close, it disables OPEN)	No effect (OPEN disabled)

(1) If maintained, it prolongs the pause until disabled by the command (timer function)

(2) If a new pulse occurs within 2 seconds after reversing, it immediately stops operation.

(3) During the partial opening cycle, an OPEN A pulse causes total opening.

NB.: Effects on other active pulse inputs in brackets.

Tab. 3/e

PULSES						
Logic "AP"	OPEN-A	OPEN-B	STOP	OPENING SAFETY DEVICES	CLOSING SAFETY DEVICES	OP/CL SAFETY DEVICE
GATE STATUS						
CLOSED	Opens the leaf and closes it after pause time	Opens single leaf and closes after pause time	No effect (OPEN disabled)	No effect (OPEN disabled)	No effect	No effect (OPEN disabled)
OPEN on PAUSE	Stops operation (3)	Stops operation (3)	Stops operation	No effect (if on part.opng., OPEN A disabled)	Reloads pause time (3) (OPEN disabled)	Reloads pause time (OPEN disabled)
CLOSING	Re-opens the leaf immediately			No effect (saves OPEN)	see paragraph 5.2.	Locks and, on release, reverts to open
OPENING	Stops operation (3)	Stops operation (3)		Reverts to close	No effect	Locks and, on release, continues opening
LOCKED	Closes the leaf (with Closing Safety devices engaged, opens at the 2nd pulse) (3)		No effect (OPEN disabled)	No effect	No effect	No effect (OPEN disabled)

Tab. 3/f

PULSES						
Logic "SP"	OPEN-A	OPEN-B	STOP	OPENING SAFETY DEVICES	CLOSING SAFETY DEVICES	OP/CL SAFETY DEVICE
GATE STATUS						
CLOSED	Opens the leaf and closes it after pause time	Opens single leaf and closes after pause time	No effect (OPEN disabled)	No effect (OPEN disabled)	No effect	No effect (OPEN disabled)
OPEN on PAUSE	Stops operation (3)	Stops operation (3)	Stops operation	No effect (if on part.opng., OPEN A disabled)	On release, closes after 5" (OPEN disabled)	On release, closes after 5" (OPEN disabled)
CLOSING	Re-opens the leaf immediately			No effect (saves OPEN)	see paragraph 5.2.	Locks and, on release, reverts to open
OPENING	Stops operation (3)	Stops operation (3)		Reverts to close	No effect (saves OPEN)	Locks and, on release, continues opening
LOCKED	Closes the leaf (3)		No effect (OPEN disabled)	No effect	No effect	No effect (OPEN disabled)

Tab. 3/g

PULSES						
Logic "B"	OPEN-A (opening)	OPEN-B (closing)	STOP	OPENING SAFETY DEVICES	CLOSING SAFETY DEVICES	OP/CL SAFETY DEVICE
GATE STATUS						
CLOSED	Opens the leaf	No effect	No effect (OPEN B disabled)	No effect (OPEN A disabled)	No effect	No effect (OPEN A disabled)
OPEN	No effect	Closes the leaf	Stops operation	No effect (saves OPEN A)	No effect (OPEN B disabled)	No effect (OPEN B disabled)
CLOSING	Reverts to open	No effect	Stops operation (OPEN-A disabled)	Stops operation (OPEN-A disabled)	Stops operation (OPEN-B disabled)	Stops operation (OPEN-A/B disabled)
OPENING	No effect	No effect	No effect (OPEN A/B disabled)	No effect (OPEN-A disabled)	No effect (OPEN B disabled)	No effect (OPEN A/B disabled)
LOCKED	Opens the leaf	Closes the leaf				

Tab. 3/h

CONTROLS ALWAYS HELD DOWN						
Logic "C"	OPEN-A (opening)	OPEN-B (closing)	STOP	OPENING SAFETY DEVICES	CLOSING SAFETY DEVICES	OP/CL SAFETY DEVICE
GATE STATUS						
CLOSED	Opens the leaf	No effect (OPEN-A disabled)	No effect (OPEN A/B disabled)	No effect (OPEN A disabled)	No effect	No effect (OPEN A disabled)
OPEN	No effect (OPEN-B disabled)	Closes the leaf	Stops operation	No effect (OPEN A disabled)	No effect (OPEN B disabled)	No effect (OPEN B disabled)
CLOSING	Stops operation	/	Stops operation	No effect	Stops operation (OPEN-B disabled)	Stops operation (OPEN-A/B disabled)
OPENING	/	Stops operation		Stops operation (OPEN-A disabled)	No effect	

- (1) If maintained, it prolongs the pause until disabled by the command (timer function)
- (2) If a new pulse occurs within 2 seconds after reversing, it immediately stops operation.
- (3) During the partial opening cycle, an OPEN A pulse causes total opening.

NB.: Effects on other active pulse inputs in brackets.

13. Prewired Enclosure

The 455D board can be easily installed in a prewired enclosure supplied by FAAC that integrates a number of functions: Power ON-OFF switch and accessory power outlet, loop detector sockets prewired to the board, large terminal strips to easily connect activations, accessories and safeties.

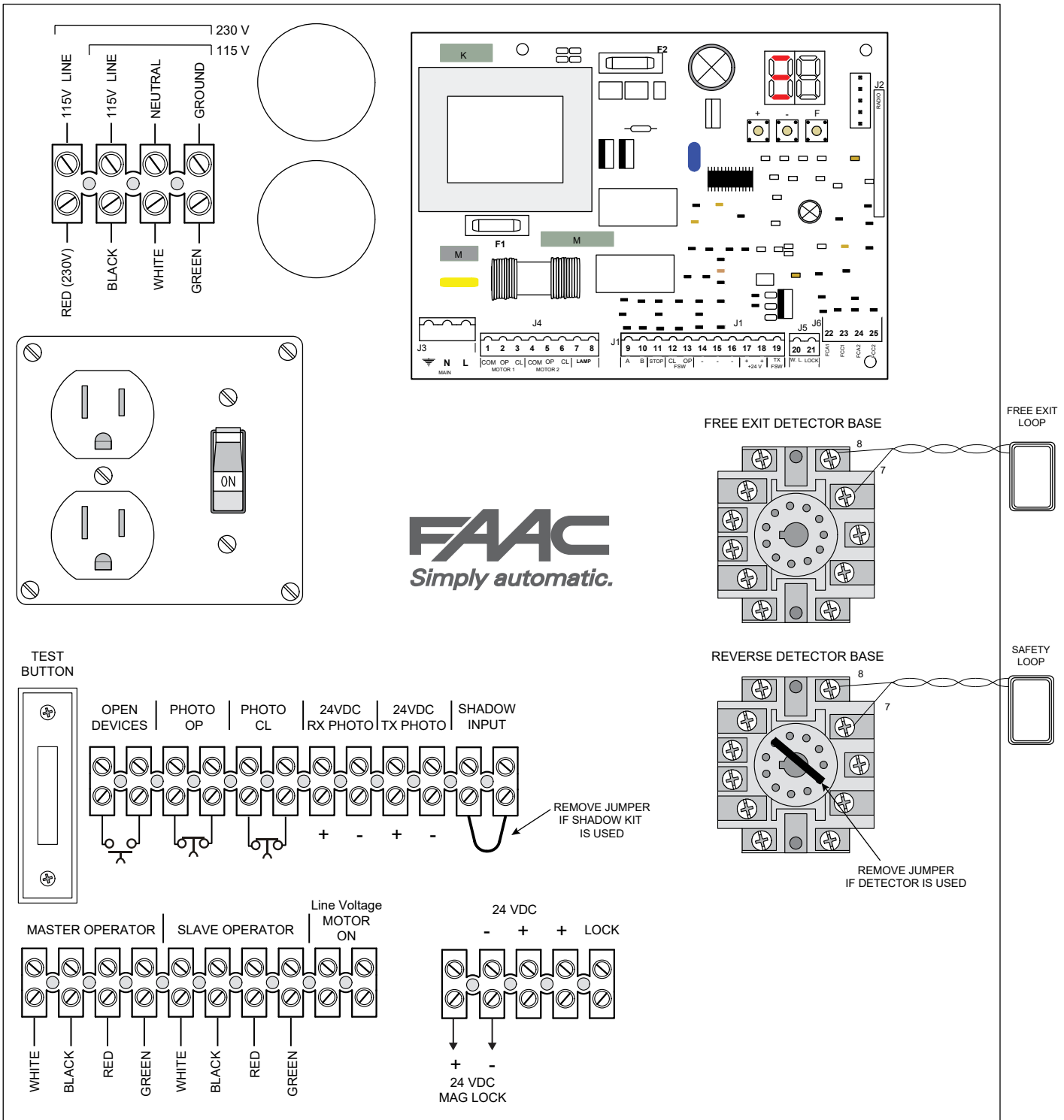

AC Power Wiring Guidelines

1. Check local wiring codes in all cases and follow all local building codes. Wiring and hookup should be performed by qualified electricians/installers only.
2. AC power should be supplied from a circuit breaker panel and must have its own dedicated circuit breaker. This supply must include a green ground conductor.
3. Properly ground the gate operator to minimize or prevent damage from power surges and/or lightning. Use a grounding rod if necessary. A surge suppressor is recommended for additional protection.

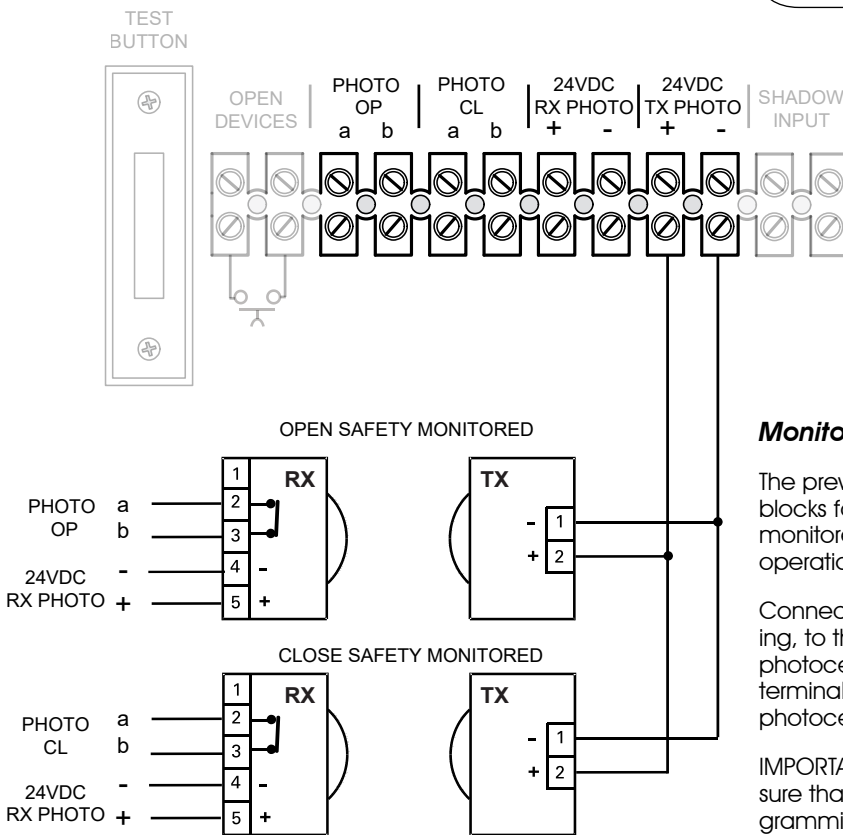
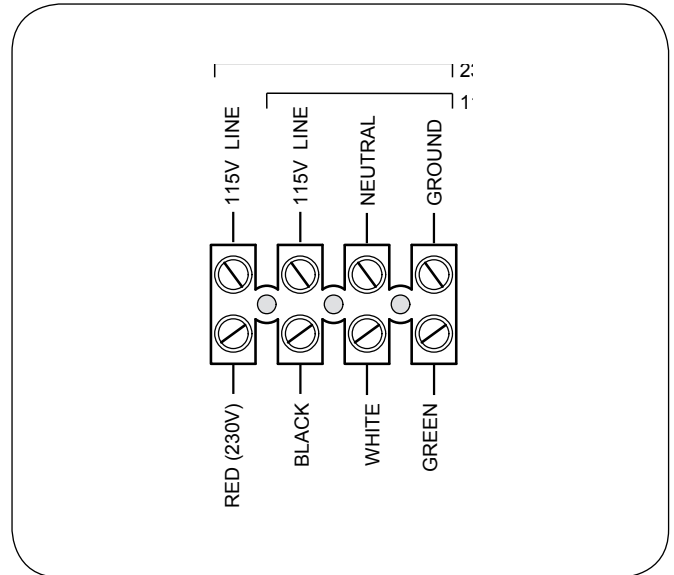

Monitored safety connections

The prewired enclosure comes with dedicated terminal blocks for the connection of safety photocells that can be monitored by the control board for presence and correct operation.

Connect the transmitter photocells as shown on the drawing, to the dedicated TX photo outputs. Connect the receiver photocells 24V power to the dedicated outputs on the terminal block as shown. Connect the N.C. outputs of the photocells to the dedicated terminal blocks.

IMPORTANT: To enable monitoring of the photocells make sure that FAIL-SAFE mode is turned on in the advanced programming menu:

ADVANCED PROGRAMMING F + +		
Display	Function	Default
F5	<p>FAIL SAFE: If this function is activated, it enables a function test of the photocells before any gate movement. If the test fails (photocells not serviceable), the gate does not start the movement.</p> <p>4 = Active n0 = Disabled</p>	n0

Maglock connection

The prewired enclosure comes with dedicated terminal blocks for the connection of a relay to drive a Maglock.

The Maglock kit can be ordered separately as an accessory. Refer to this schematic for the connections.

If using non-FAAC relay make sure the minimum switch voltage is less than 12Vac

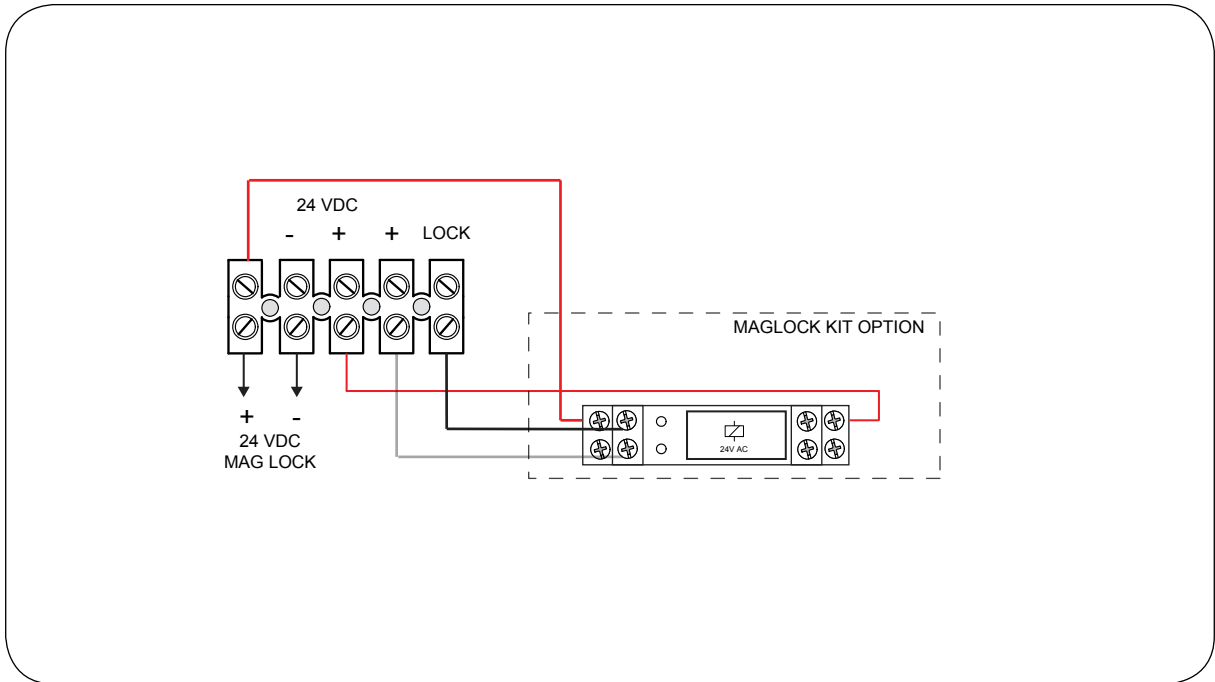

Shadow Loop kit option

The prewired enclosure comes with dedicated terminal blocks for the connection of a relay and a loop detector socket to implement the shadow loop functionality. The Shadow loop kit can be ordered separately as an accessory.

Refer to this schematic for the connections.

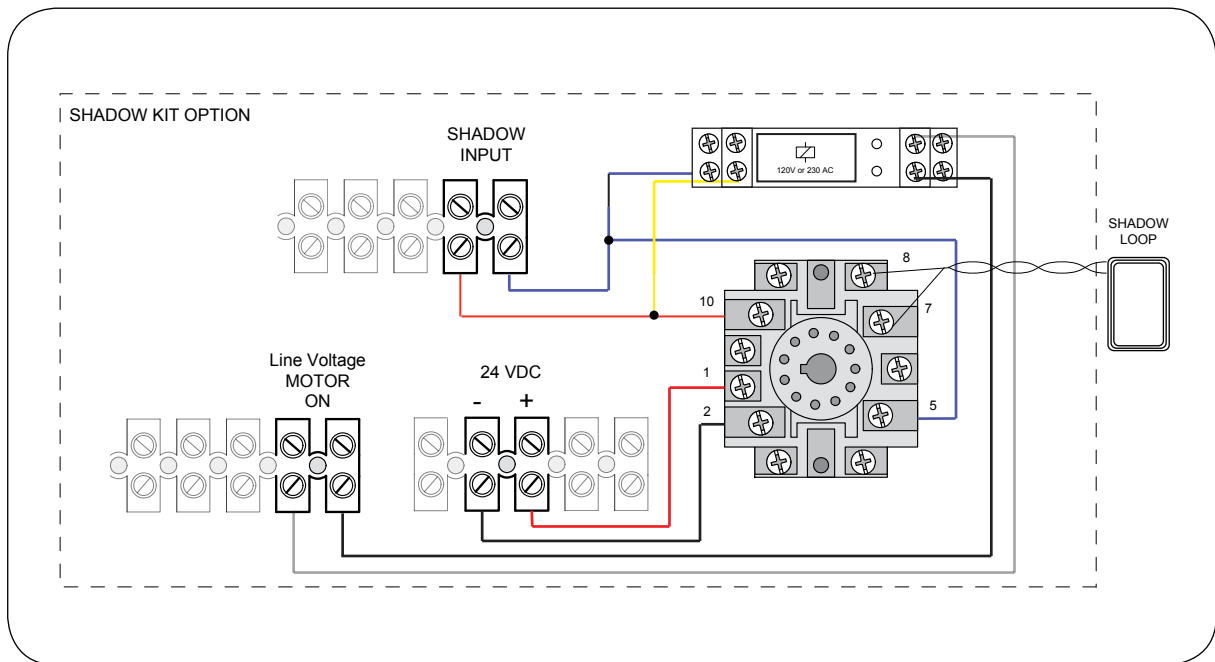

LIMITED WARRANTY

To the original purchaser only:

FAAC International, Inc., warrants, for twenty-four (24) months from the date of invoice, the gate operator systems and other related systems and equipment manufactured by FAAC S.p.A. and distributed by FAAC International, Inc., to be free from defects in material and workmanship under normal use and service for which it was intended provided it has been properly installed and operated.

FAAC International, Inc.'s obligations under this warranty shall be limited to the repair or exchange of any part of parts manufactured by FAAC S.p.A. and distributed by FAAC International, Inc. Defective products must be returned to FAAC International, Inc., freight prepaid by purchaser, within the warranty period. Items returned will be repaired or replaced, at FAAC International, Inc.'s option, upon an examination of the product by FAAC International, Inc., which discloses, to the satisfaction of FAAC International, Inc., that the item is defective. FAAC International, Inc. will return the warranted item freight prepaid. The products manufactured by FAAC S.p.A. and distributed by FAAC International, Inc., are not warranted to meet the specific requirements, if any, of safety codes of any particular state, municipality, or other jurisdiction, and neither FAAC S.p.A. or FAAC International, Inc., assume any risk or liability whatsoever resulting from the use thereof, whether used singly or in combination with other machines or apparatus.

Any products and parts not manufactured by FAAC S.p.A. and distributed by FAAC International, Inc., will carry only the warranty, if any, of the manufacturer. This warranty shall not apply to any products or parts thereof which have been repaired or altered, without FAAC International, Inc.'s written consent, outside of FAAC International, Inc.'s workshop, or altered in any way so as, in the judgment of FAAC International, Inc., to affect adversely the stability or reliability of the product(s) or has been subject to misuse, negligence, or accident, or has not been operated in accordance with FAAC International, Inc.'s or FAAC S.p.A.'s instructions or has been operated under conditions more severe than, or otherwise exceeding, those set forth in the specifications for such product(s). Neither FAAC S.p.A. nor FAAC International, Inc., shall be liable for any loss or damage whatsoever resulting, directly or indirectly, from the use or loss of use of the product(s). Without limiting the foregoing,

this exclusion from liability embraces a purchaser's expenses for downtime or for making up downtime, damages for which the purchaser may be liable to other persons, damages to property, and injury to or death of any persons.

FAAC S.p.A. or FAAC International, Inc., neither assumes nor authorizes any person to assume for them any other liability in connection with the sale or use of the products of FAAC S.p.A. or FAAC International, Inc. The warranty herein above set forth shall not be deemed to cover maintenance parts, including, but not limited to, hydraulic oil, filters, or the like. No agreement to replace or repair shall constitute an admission by FAAC S.p.A. or FAAC International, Inc., of any legal responsibility to effect such replacement, to make such repair, or otherwise. This limited warranty extends only to wholesale customers who buy directly through FAAC International, Inc.'s normal distribution channels. FAAC International, Inc., does not warrant its products to end consumers.

Consumers must inquire from their selling dealer as to the nature and extent of that dealer's warranty, if any. This warranty is expressly in lieu of all other warranties expressed or implied including the warranties of merchantability and fitness for use. This warranty shall not apply to products or any part thereof which have been subject to accident, negligence, alteration, abuse, or misuse or if damage was due to improper installation or use of improper power source, or if damage was caused by fire, flood, lightning, electrical power surge, explosion, wind storm, hail, aircraft or vehicles, vandalism, riot or civil commotion, or acts of God.