

R-6 INSTALLATION INSTRUCTIONS AND SAFETY INFORMATION

FOR THE VIKING R-6 GATE OPERATOR



UL 325 CLASS I COMPLIANT
**Residential Vehicular
Swing Gate Operator**



VIKING ACCESS SYSTEMS™

VIKING ACCESS SYSTEMS™

VIKING ACCESS SYSTEMS™

STANDARD FEATURES AND OPERATOR SPECIFICATIONS

- Mechanical gate release handle
- Plated and powder coated steel chassis
- Adjustable travel speed
- Opening up to 120°
- 100% duty cycle
- 400 cycles of operation on backup battery (600 lb. gate)
- Intelligent speed control with smooth start and stop, self-adjust system
- Hold Open Timer to automatically close the gate
- Intelligent obstruction detection with adjustable sensitivity
- Modular connectors for easy access control and accessory installation
- Regulated power supply for your external accessories
- LED indicators display gate and operator status for easy troubleshooting
- On-Board LCD Display provides diagnostics, operator status, settings and real-time volt and amp readings
- Built-in motor heater for cold weather applications
- Equipped for 115/230 VAC, 24 VAC/VDC and Solar power supplies

THE VIKING R-6™ SWING GATE OPERATOR

TABLE OF CONTENTS:

IMPORTANT SAFETY INFORMATION	2-9
Important Safety Instructions.....	2
Important Installation Instructions.....	2-3
Maintenance.....	4
General Safety Precautions.....	4-5
UL 325 Gate Operator Classifications.....	5
Monitored Entrapment Protection Requirements.....	6
Monitored Entrapment Protection Installation.....	7
Manual Release.....	7
Audible Alarm Reset Installation.....	8
Warning Placard Installation.....	9
SPECIFICATIONS	10
CONTROL BOARD REFERENCES	11
GATE OPERATOR INSTALLATION	12-15
Concrete Pad Option.....	12
Post Mounting Option.....	13
Operator Positioning.....	14-15
ELECTRICAL INSTALLATION	16-18
High Voltage Supply Option.....	16
Low Voltage Supply Option.....	17
Solar Supply Option.....	17
Monitored UL Sensor Connections.....	18
LIMITS SETUP	19
PRIMARY/SECONDARY SET UP	20-21
Two Wire Communication.....	20
Wireless Communication Options.....	21
CONTROL BOARD SETUP	22-25
Initial Settings.....	22-23
Obstruction Detection Sensor (ODS).....	24
Heater, Lock Mode.....	25
ACCESSORY CONNECTIONS	26-33
Access Control Connections.....	26-27
Radio Receiver.....	28
Photocell.....	29
Viking Loop Rack.....	30
Guidelines for Loop Installations.....	31
Magnetic Lock, Lock Solenoid.....	32
Barrier Arm Synchronization Option.....	33
TROUBLESHOOTING	34-40
LED References.....	34-35
LCD Display References.....	36-39
Solutions.....	40
PARTS DIAGRAM/PARTS LIST	41
LIMITED WARRANTY	42-43
VIKING ACCESSORIES	44

IMPORTANT SAFETY INFORMATION

 **WARNING! Not Following these instructions may cause severe injury or death.**

IMPORTANT SAFETY INSTRUCTIONS

 **WARNING! To reduce the risk of severe injury or death.**

1. READ AND FOLLOW ALL INSTRUCTIONS.
2. Never let children operate or play with gate controls. Keep the remote away from children.
3. Always keep people and objects away from the gate. **NO ONE SHOULD CROSS THE PATH OF THE MOVING GATE.**
4. Test the gate operator monthly. The gate **MUST** reverse on contact with a rigid object or stop when an object activates the non-contact sensors. After adjusting the force or the limit of travel, retest the gate operator. Failure to adjust and retest the gate operator properly can increase the risk of severe injury or death.
5. Use the manual release only when the gate is not moving.
6. **KEEP GATES PROPERLY MAINTAINED.** Read the user's manual. Have a qualified service person make repairs to gate hardware.
7. The entrance is for vehicles only. Pedestrians must use a separate entrance.
8. **Every gate operator installation MUST have secondary protection devices against entrapment, such as edge sensors and photo beams more in particular in places where the risk of entrapment is more likely to occur.**
9. SAVE THESE INSTRUCTIONS.

IMPORTANT INSTALLATION INSTRUCTIONS

1. Install the gate operator only when:
 - a. The operator is appropriate for the construction of the gate and usage Class of the gate (refer to page 5),
 - b. All openings of a horizontal slide gate are guarded or screened from the bottom of the gate to a minimum of 6 feet (1.83 m) above the ground to prevent a 2-1/4 inch (57.2 mm) diameter sphere from passing through the openings anywhere in the gate, and in that portion of the adjacent fence that the gate covers in the open position,
 - c. **ALL EXPOSED PINCH POINTS ARE ELIMINATED OR GUARDED, AND**
 - d. **GUARDING IS SUPPLIED FOR EXPOSED ROLLERS. .**
2. The operator is intended for installation only on gates used for vehicles. Pedestrians must be supplied with a separate access opening. The pedestrian access opening shall be designed to promote pedestrian usage. Locate the gate such that persons will not come in contact with the vehicular gate during the entire path of travel of the vehicular gate.
3. The gate must be installed in a location so that enough clearance is supplied between the gate and adjacent structures when opening and closing to reduce the risk of entrapment. Swinging gates shall not open in to the public access areas.
4. The gate must be properly installed and work freely in both directions prior to the installation of the gate operator. Do not over-tighten the operator clutch or pressure relief valve to compensate for a damaged gate.
5. The gate operator controls must be placed so that the user has full view of the gate area when the gate is moving **AND AWAY FROM THE GATE PATH PERIMETER.**

IMPORTANT SAFETY INFORMATION

⚠ WARNING! Not Following these instructions may cause severe injury or death.

IMPORTANT SAFETY INSTRUCTIONS (Continued)

6. Controls intended for user activation must be located at least six feet (6') away from any moving part of the gate and where the user is prevented from reaching over, under, around or through the gate to operate the controls. *Exception:* Emergency access controls only accessible by authorized personnel (i.e. fire, police, EMS) may be placed at any location in the line-of-sight of the gate.
7. The Stop and/or Reset button must be located in the line-of-sight of the gate. Activation of the reset control shall not cause the operator to start.
8. A minimum of two (2) WARNING SIGNS shall be installed, in the area of the gate. Each placard is to be visible by persons located on the side of the gate on which the placard is installed.
9. **For gate operators using non-contact sensors (photoelectric beam or like) in accordance with section 32.1.1 of the UL standard:**
 - a. See instructions on the placement of non-contact sensors for each type of application (refer to page 6).
 - b. Care shall be exercised to reduce the risk of nuisance tripping, such as when a vehicle, trips the sensor while the gate is still moving, and
 - c. One or more non-contact sensors shall be located where the risk of entrapment or obstruction exists, such as the perimeter reachable by a moving gate or barrier (refer to page 6).
 - d. For UL compliance: Use Only - Omron: E3K-R10K4-NR-1 // EMX: IRB-RET, IRB-MON // Miller Edge: RG-K-R, PG-K-R100, PG-K-R50, MIM-62
For ETL compliance: The following can also be used - Viking: FA-XP30-10K // Seco-Larm E-931-33PRGQ, E-936-S45RRGQ, E-931-S50RRGQ, E-960-D90GGQ // EMX NIR-50-325
10. **For a gate operator utilizing a contact sensor (edge sensor or like) in accordance with section 32.1.1 of the UL 325 standard:**
 - a. One or more contact sensors shall be located where the risk of entrapment or obstruction exists, such as a the leading edge, trailing edge, and post mounted both inside and outside of a vehicular horizontal slide gate (refer to page 6).
 - b. One or more contact sensors shall be located at the bottom of a vehicular vertical lift gate.
 - c. One or more contact sensors shall be located at the pinch point of a vehicular vertical pivot gate.
 - d. A hardwired contact sensor shall be located and its wiring arranged so that the communication between the sensor and the gate operator is not subject to mechanical damage.
 - e. A wireless contact sensor such as one that transmits radio frequency (RF) signals to the gate operator for entrapment protection functions shall be located where the transmission of the signals are not obstructed or impeded by building structures, natural landscaping or similar obstructions. A wireless contact sensor shall function under the intended end-use conditions.
 - f. One or more contact sensors shall be located on the inside and outside leading edge of a swing gate. Additionally, if the bottom edge of a swing gate is greater than 4 inches (101.6 mm) but less than 16 inches (406 mm) above the ground at any point in its arc of travel, one or more contact sensors shall be located on the bottom edge.
 - g. One or more contact sensors shall be located at the bottom edge of a vertical barrier (arm).
 - h. For UL compliance: Use only - EMX: WEL-200K // Miller Edge: ME117, ME120, ME123, MG020, MGR20, MGS20, RB-G-K10, MIM-62
For ETL compliance: The following can also be used - ASO: 25.30, 25.45, 95.20 // Miller Edge: ME110

IMPORTANT SAFETY INFORMATION

 **WARNING! Not Following these instructions may cause severe injury or death.**

MAINTENANCE

Remove the Power Harness from the Control Board. (refer to page 16)

- Clean and lubricate the turning pins and gate hinges using the recommended lubricant.
- Check that all mounting hardware of the gate operator is properly tighten.
- Ensure that the gate moves freely.
- Check for corroded parts and replace if necessary.
- Check the battery for the following:
 - Battery connections must be free of corrosion.
 - Battery voltage must be 26VDC (fully charged battery).

Reconnect the Power Harness for the Control Board. (refer to page 16)

- Check and confirm the proper operation of all safety devices (photoelectric eye, edge sensors or like).
- Check and confirm the operation of all installed accessories.
- Check and confirm the operation of all special features such as the Intelligent Obstruction Sensor and Hold Open Timer. (refer to pages 22-24)
- Check and confirm the operation of the manual release. (refer to page 7)
- Verify the functionality of the battery backup, or power failure option, by turning off the main power source (115VAC or 230VAC). **DO NOT FORGET TO TURN ON THE MAIN POWER SOURCE AFTER VERIFICATION.**

GENERAL SAFETY PRECAUTIONS

The following precautions are an integral and essential part of the product and must be supplied to the user. Read them carefully as they contain important indications for the safe installation, use and maintenance.

- These instruction must be kept and forwarded to all possible future users of the system.
- This product must be used only for that which it has been expressly designed.
- Any other use is to be considered improper and therefore dangerous.
- The manufacturer cannot be held responsible for possible damage caused by improper, erroneous or unreasonable use.
- Avoid operating in the proximity of the hinges or moving mechanical parts.
- Do not enter the path of the moving gate while in motion.
- Do not obstruct the motion of the gate as this may cause a situation of danger.
- Do not allow children to play or stay within the path of the moving gate.
- Keep remote control or any other control devices out of the reach of children, in order to avoid possible involuntary activation of the gate operator.
- In case of break down or malfunctioning of the product, disconnect from the main power source. Do not attempt to repair or intervene directly, contact only qualified personnel for repair.
- Failure to comply with the above may create a situation of danger.
- All cleaning, maintenance or repair work must be carried out by qualified personnel.
- In order to guarantee that the system works efficiently and correctly it is important to have the manufacturer's instructions on maintenance of the gate and operator carried out by qualified personnel.
- In particular, regular checks are recommended in order to verify that the safety devices are operating correctly.

All installation, maintenance and repair work must be documented and made available to the user.

IMPORTANT SAFETY INFORMATION

⚠ CAUTION: To Reduce the Risk of Fire or Injury to Persons:

GENERAL SAFETY PRECAUTIONS (Continued)

- Use only the following type and size battery(ies): Yuasa NP7-12 or VIKING DUBA12
- Do not dispose of the battery(ies) in fire. The cells may explode. Check with local codes for possible disposal instructions.
- Do not open or mutilate the battery(ies). Released electrolyte is corrosive and may cause damage to the eyes or skin. It may be toxic if swallowed.
- Exercise care in handling batteries in order not to short the battery with conducting materials such as rings, bracelets and keys.
- Change the battery(ies) provided with or identified for use with this product only in accordance with the instructions and limitations specified in this manual.
- Observe proper polarity orientation between the battery(ies) and charging circuit.
- Do not mix batteries of different sizes or from different manufactures in this product (applies to products employing more than one user replaceable secondary battery).
- A battery-operated product employing a secondary battery supply intended to be charged within the product shall contain specific instructions concerning the proper method of charging.

UL 325 Gate Operator Classifications

GLOSSARY

RESIDENTIAL VEHICULAR GATE OPERATOR

CLASS I - A vehicular gate operator (or system) intended for use in garages or parking areas associated with a residence of one-to four single families.

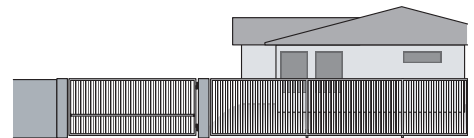

COMMERCIAL/GENERAL ACCESS VEHICULAR GATE OPERATOR

CLASS II - A vehicular gate operator (or system) intended for use in a commercial location or building such as a multi-family housing unit (five or more single family units), hotel, garages, retail store, or other building servicing the general public.

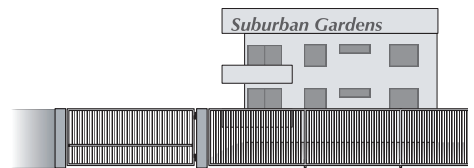

INDUSTRIAL/LIMITED ACCESS VEHICULAR GATE OPERATOR

CLASS III - A vehicular gate operator (or system) intended for use in an industrial location or building such as a factory or loading dock area or other locations not accessible by or intended to service the general public.

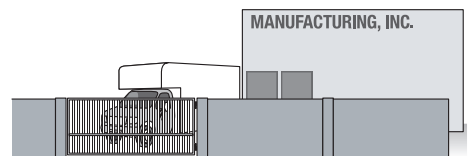

RESTRICTED ACCESS VEHICULAR GATE OPERATOR

CLASS IV - A vehicular gate operator (or system) intended for use in a guarded industrial location or building such as an airport security area or other restricted access locations not servicing the general public, in which unauthorized access is prevented via supervision by security personnel.

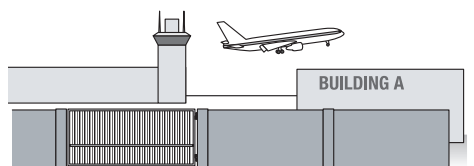

Install the gate operator only when:

The operator is appropriate for the construction of the gate and the Usage Class of the gate.

IMPORTANT SAFETY INFORMATION

⚠ WARNING! Not Following these instructions may cause severe injury or death.

Monitored Entrapment Protection Requirements

IMPORTANT: MONITORED PROTECTION MUST BE INSTALLED

- **REQUIRED BY UL 325, an approved MONITORED entrapment protection sensor is REQUIRED to be installed in all areas accessible to potential entrapment and pinch points.**
- For a horizontal swing gate operator, at least one Monitored External Entrapment Sensor is required in each direction of travel. Except, if there is no entrapment zone in one direction of travel, it is not required to have a Monitored Entrapment sensor for that direction of travel.
 - ⚠ If there is a possible entrapment zone in the open direction, an external sensor **MUST** be connected to the “UL” input or the installation will not comply with UL 325.
 - ⚠ An external sensor connected to the “Re-Open” input terminal will protect against entrapment **ONLY** in the closing direction.
- The installed sensor **MUST** be “**10K Resistor Based**”.
- You may connect up to **FOUR** monitored sensors, wired in parallel, to either the “UL” and/or “Re-Open” terminals, for a total of 8 monitored sensors.
- **Failure to install the required monitored entrapment protection sensor(s) may render the gate operator INOPERABLE. The gate can be moved manually. Refer to page 7.**
- Consult the installation manual of the sensor for detailed information about the usage, installation and maintenance.
- Use only UL and/or ETL Recognized Edge Sensors and Photoelectric Sensors. Refer to pg 3.

SWING GATE ENTRAPMENT ZONE – Locations between a moving gate or moving, exposed operator components and a counter opposing edge or surface where entrapment is possible up to 1.8 m (6 ft) above grade. Such locations occur if during any point in travel:

- a. The gap between the bottom of a moving gate and the ground is greater than 101.6 mm (4 in) and less than 406 mm (16 in); or
- b. The distance between the center line of the pivot and the end of the wall, pillar, or column to which it is mounted when in the open or closed position exceeds 101.6 mm (4 in). Any other gap between a moving gate and fixed counter opposing edges or surfaces or other fixed objects is less than 406 mm (16 in) (examples are walls, curbs, berms or other immovable objects).

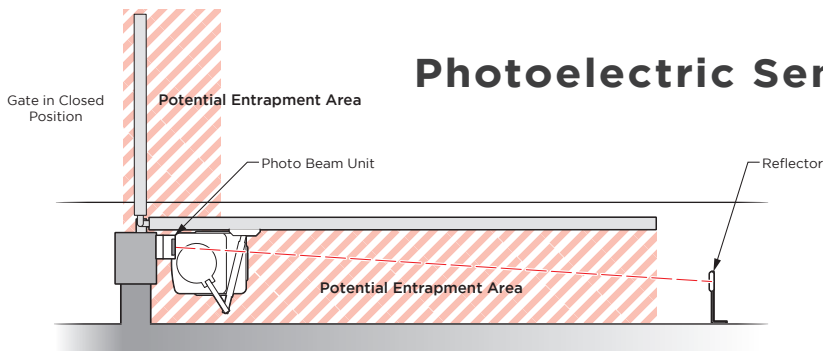

Photoelectric Sensor (non-contact sensor)

Edge Sensor (contact sensor)

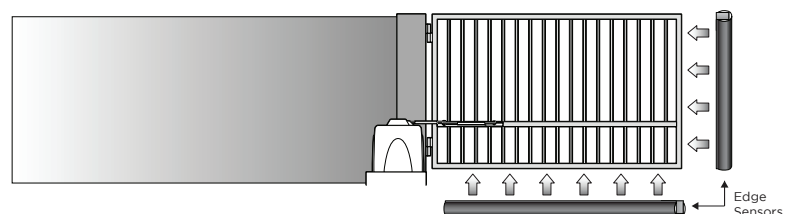

IMPORTANT SAFETY INFORMATION

⚠ WARNING! Not Following these instructions may cause severe injury or death.

Monitored Entrapment Protection Installation

⚠ IMPORTANT: A minimum of one Monitored External Entrapment Sensor is required to be connected to the UL terminal OR the Re-Open terminal. If there is a possible entrapment zone in the open direction, an external sensor **MUST** be wired to the “UL” input or the installation will not comply with UL 325.

“UL” Protects against entrapment in both the opening and closing directions. Input will reverse the gate momentarily in the opposite direction it was traveling. Refer to page 18.

“Re-Open” Protects against entrapment in the closing direction **ONLY**. Input will reverse the gate all the way to the Open Limit. Refer to page 18.

STEP 1: Connect the monitored entrapment protection sensor(s) to the Viking Control Board.

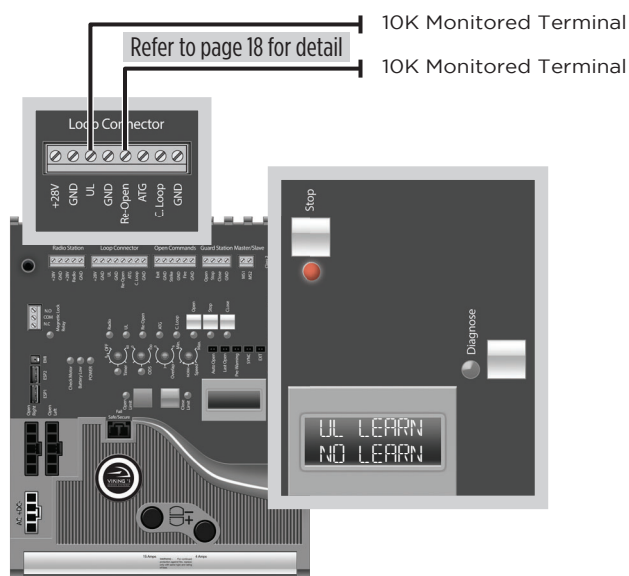

STEP 2:

Execute the Learn Process:

- Press and release the “Diagnose” button until you see UL LEARN NO LEARN on the LCD Display.
- Press and hold the “Stop” button.
- Toggle the “Diagnose” button once.
- The number of Monitored sensors connected to the “UL” or “Re-Open” terminals will now be displayed.

EXAMPLE: UL LEARN
 UL2 RO1

UL SENSOR ERRORS:

If a problem occurs with one of the monitored entrapment sensors, the “Stop” LED will illuminate and an ERR message will be displayed, indicating which input terminal(s) the sensor is connected to.

TERMINAL:	“UL”	“Re-Open”	“UL” & “Re-Open”
ERROR MESSAGE:	ERR SENS UL	ERR SENS RO	ERR SENS UL RO

Manual Release

When manual operation is required:

1. Remove the “Output Shaft Cover” or Hat.
2. Lift the “Manual Release Handle”.
3. Remove the “Clutch Key”.

To resume normal operation:

1. Align the notches on the Output Shaft to the clutch and reinstall the Clutch Key.
2. Push the Manual Release Handle down, back to the locked position. **Refer to page 15 for more details.**

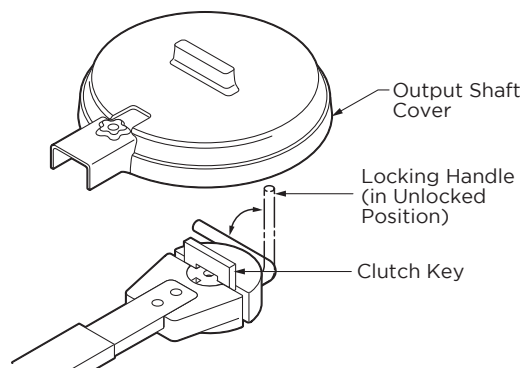

IMPORTANT SAFETY INFORMATION

⚠ WARNING! Not Following these instructions may cause severe injury or death.

Audible Alarm Reset Switch Installation

Manual Reset for the Audible Alarm

- UL 325 standard requires an audible alarm to sound after two consecutive events detected by the inherent entrapment protection of the gate operator (obstruction sensor).
- The audible alarm will continue to sound for 5 minutes or until a stop command is actuated.
- The Stop command can be actuated in two different forms:
 1. Using the Built in Stop switch on the Control Board or;
 2. Using an External Stop button within the sight of the gate, away from moving parts of the gate and out of reach of children.
 - a. Controls intended for user activation must be located at least six feet (6') away from any moving part of the gate and where the user is prevented from reaching over, under, around or through the gate to operate the controls. Outdoor or easily accessible controls shall have a security feature to prevent unauthorized use.
 - b. The Stop and/or Reset button must be located in the line-of-sight of the gate. Activation of the reset control shall not cause the operator to start.

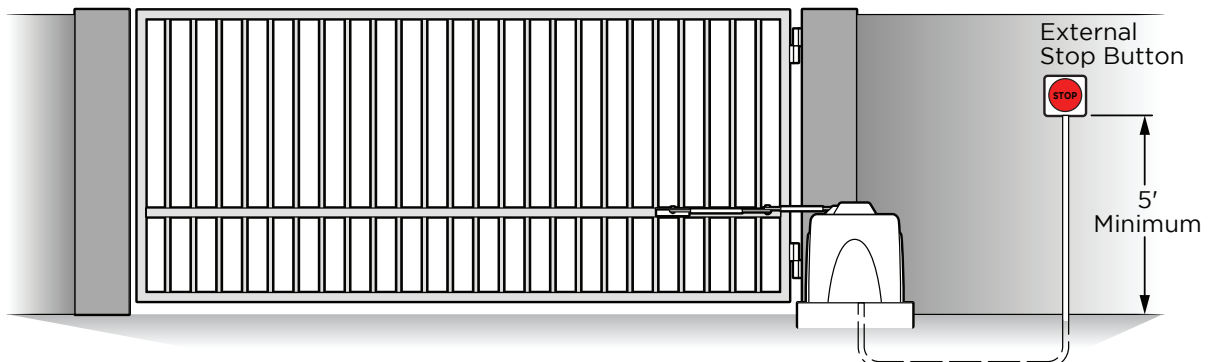
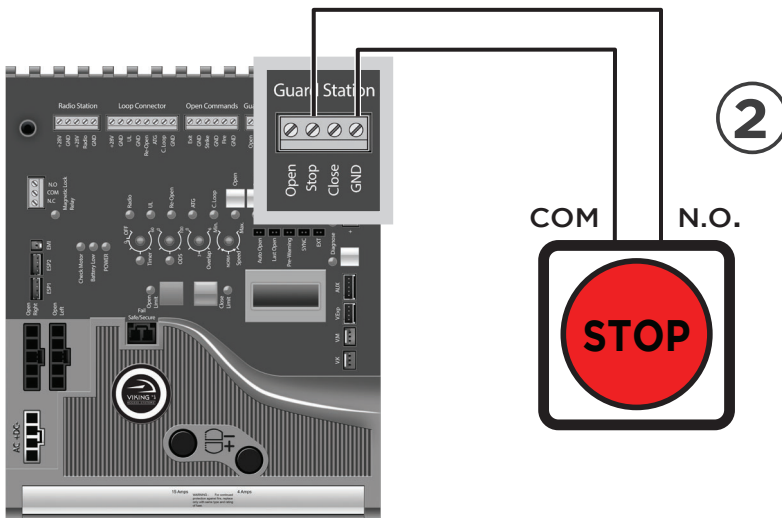

IMPORTANT SAFETY INFORMATION

⚠ WARNING! Not Following these instructions may cause severe injury or death.



DO NOT allow pedestrian use of this gate

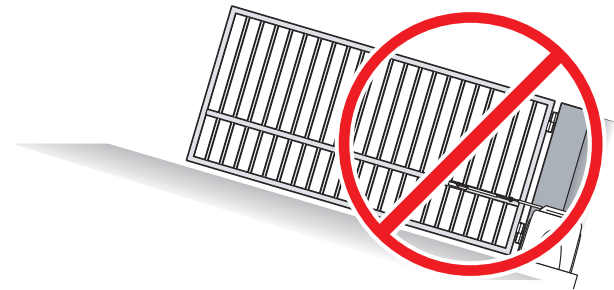

DO NOT install the gate operator to lift gates

Locate Control Buttons

- Within sight of the gate,
- At a minimum height of 5 feet so small children are not able to reach it; and
- At least 6 feet away from all moving parts of the gate.



Warning Placard Installation

- All Warning Placards must be installed where visible in the area of the gate.
- A minimum of two placards shall be installed.
- A placard is to be installed in the area of each side of the gate and be visible.



SPECIFICATIONS

SPECIFICATIONS

Max Gate Length	14 Feet	Main Power Frequency	50Hz / 60Hz
Max Gate Weight	700 lbs	Main Power Fuse	4.0A Timed
UL 325 Classification	Class I *refer to page 5	Alternative Power	24VAC/VDC (60VA) or Solar
Duty Cycle	100%	Accessory Power	24VDC (750mA)
Operating Voltage	24VDC	Power Consumption	70mA
Main Power Source	120VAC / 240VAC Single Phase	Motor Current Draw - Typical	4.0A
Main Power Current	2.5A / 1.5A	Operating Temperature	-20°F (-28°C) to 160°F (71°C)

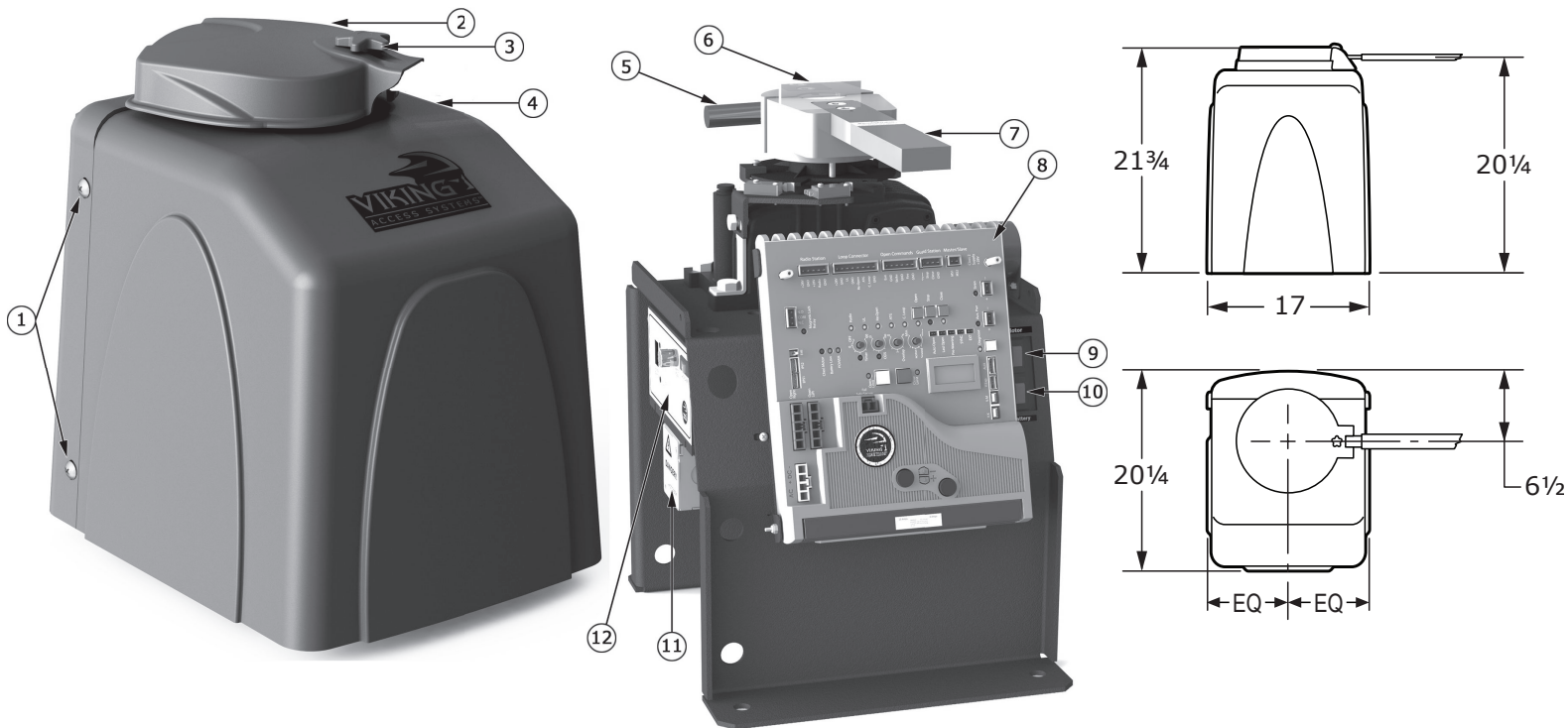

1. COVER BOLTS
2. OUTPUT SHAFT COVER (HAT)
3. OUTPUT SHAFT KNOB
secures Hat; remove to access manual release
4. MAIN COVER ASSEMBLY
5. MANUAL RELEASE HANDLE
releases the clutch to allow for manual operation
6. CLUTCH KEY
install if application does not require clutch to slip; remove to manually operate the gate
7. OUTPUT ARM
connects the Arm Assembly to Clutch & Handle Assembly
8. VFLEX CONTROL BOARD
9. MOTOR SWITCH
discontinues power to the motor; also serves as a breaker that will self-trip to protect the motor circuitry
10. BATTERY SWITCH
disconnects batteries from the charging circuit during troubleshooting
11. J-BOX
high voltage power supply connection
12. POWER SUPPLY PANEL ASSEMBLY
convenient access to main power supply switches, status indicators and EMI Fuse

GATE OPERATOR INSTALLATION

Concrete Pad Option

1. Follow the local building code to determine the required depth of the concrete pad.
2. Pad measurements recommended by Viking Access Systems are at least 24" long, 22" wide and 30" deep to ensure the stable operation of the operator, and a minimum of 6" above level grade to avoid any flooding of the machinery.
3. Provide a sufficient number of conduit pathways for all low power accessories such as loop detector leads, maglock, non-contact sensors, contact sensors, safety and other commands. Also provide conduit for the power supply to the operator.

⚠ DO NOT run low voltage and high voltage wiring in the same conduit.

⚠ Provide at least 12" separation between low and high voltage conduits.

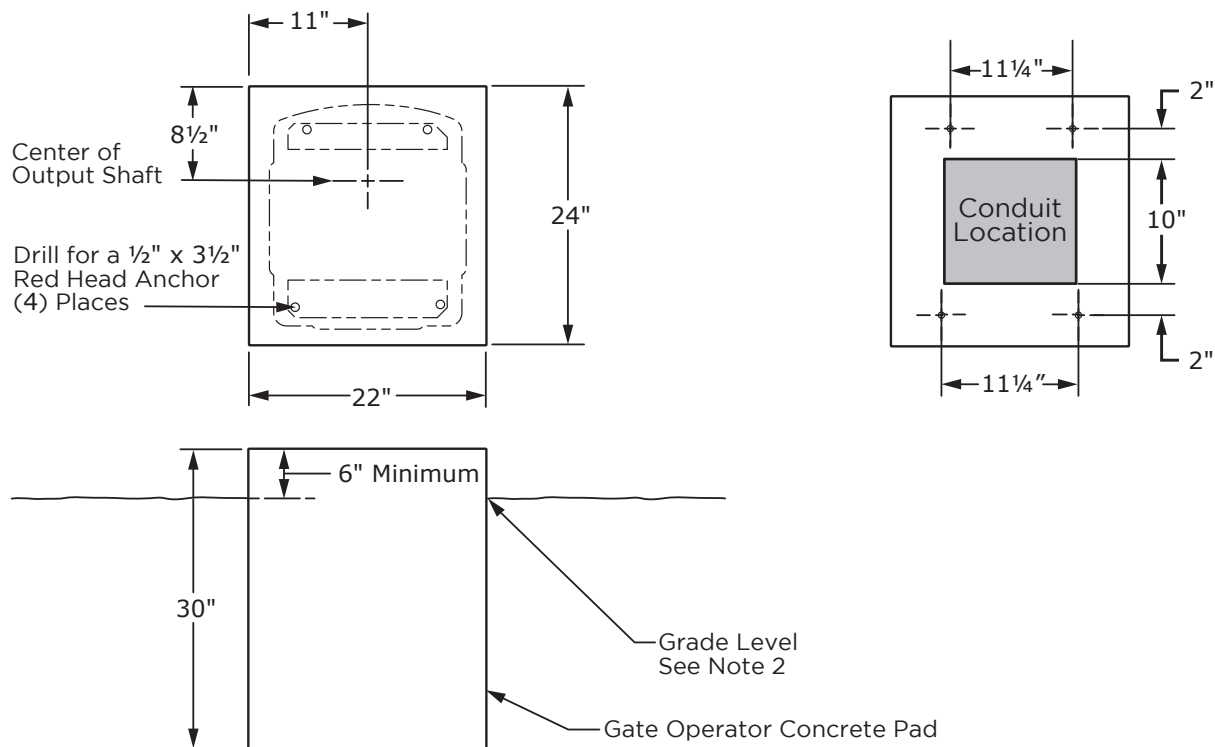

GATE OPERATOR INSTALLATION

Post Mounting Option

TIP: The operator can be post mounted to be elevated above snow and flood lines.

1. Consult the local building codes for the depth and concrete requirements.
2. Maximum 3.00" OD pipe.
3. Provide a sufficient number of conduit pathways for all low power accessories. Also provide conduit for the power supply to the operator.

⚠ DO NOT run low voltage and high voltage wiring in the same conduit.

⚠ Provide at least 12" separation between low and high voltage conduits.

REQUIRED ADD-ON: PART# VA-F1PS

- Main pieces made of 1/4" thick material
- All mounting hardware is included
- Posts and U-Bolts are not supplied

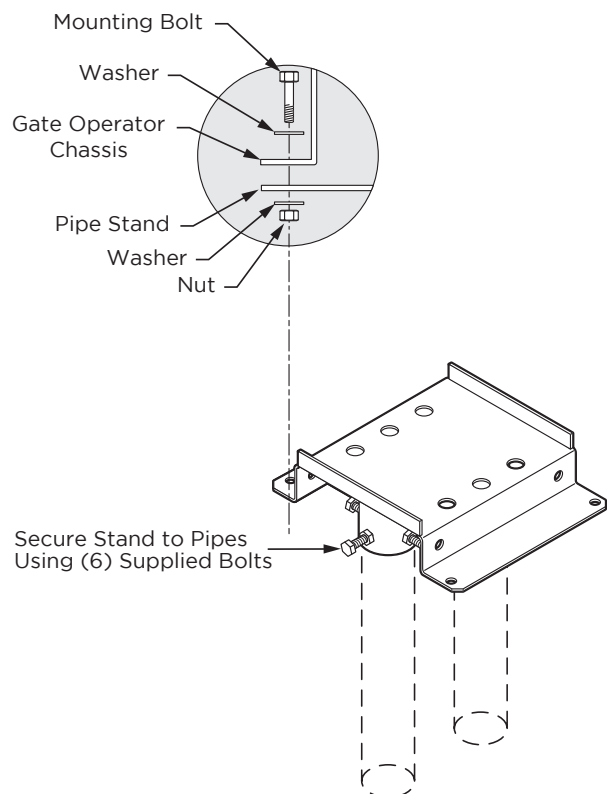
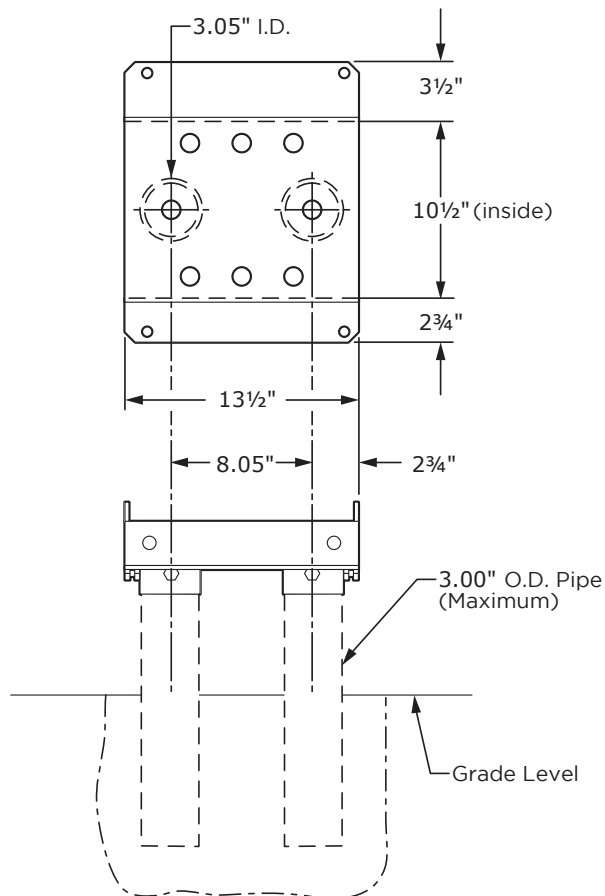

GATE OPERATOR INSTALLATION

Operator Positioning

⚠ IMPORTANT: Swing Gates must not open into public access areas.

The gate must be installed in a location so that enough clearance is supplied between the gate, while opening and closing, and adjacent structures to reduce the risk of entrapment.

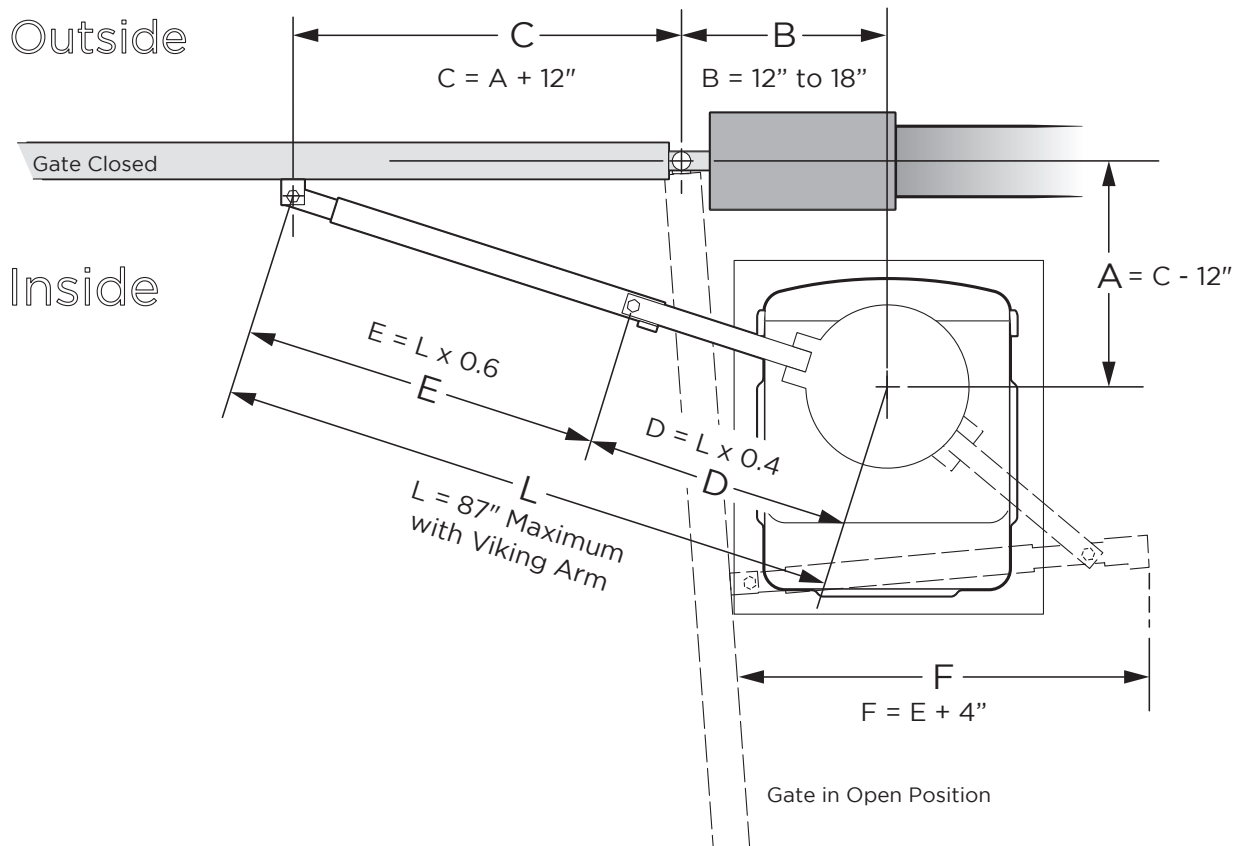

⚠ TECHNICAL TIPS: Operator and Arm Geometry

- Increasing “C” dimension provides better gate control and stability by reducing the effects of inertia and decreasing the gate leverage against the operator.
- Following to the geometrical formulas and relationships provided is recommended.

Arm Assembly: VA-F1ARM20

Gate must travel level.

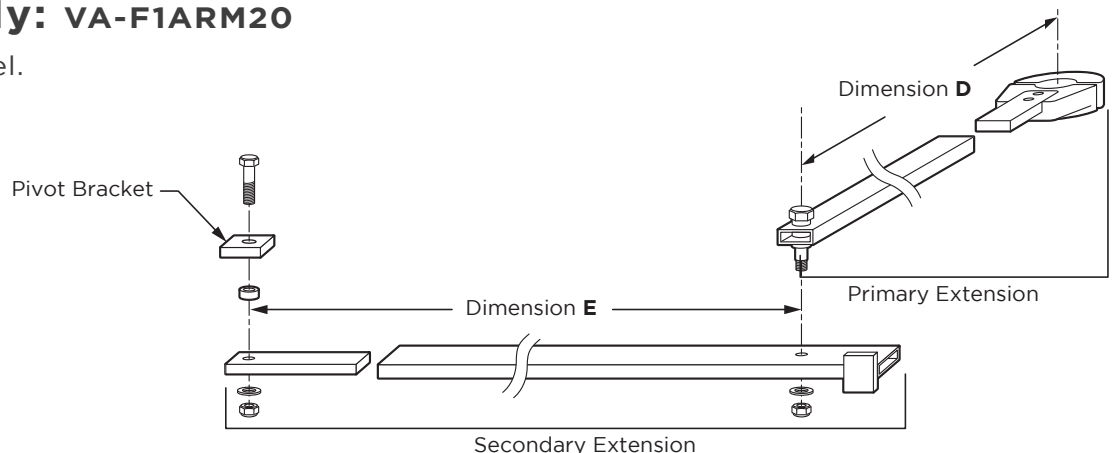

GATE OPERATOR INSTALLATION

⚠ IMPORTANT: When attaching the Arm Assembly to the gate, if the “Gate Bracket” is not welded to a frame member that runs the full length of the gate, the operator may damage the gate. Do not attach the Gate Bracket to only a few pickets.

STEP 1

Install the Clutch and cut the Arm Assembly to achieve the desired dimensions for “D” and “E” according to the formulas provided.

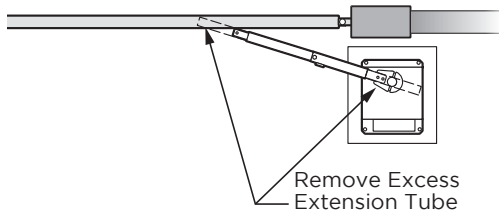

⚠ TIP: Leave some additional material when cutting the Arm Assembly to allow for adjustment.

STEP 2

With the gate at the closed, install the Arm Assembly. Check that the dimensions correspond accordingly to the formulas provided.

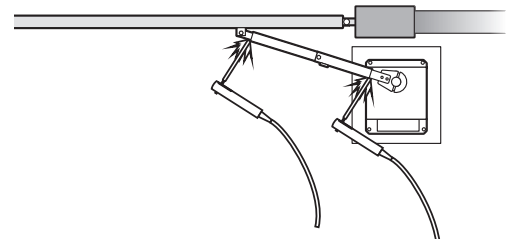

⚠ TIP: Use C-clamps or tack-weld the Arm assembly in place until Step 3 has been completed.

STEP 3

With the Clutch installed and released, manually move the gate to both limits. Verify the following:

1. The gate reaches the desired limits.
2. The Arm does not bind at any point.

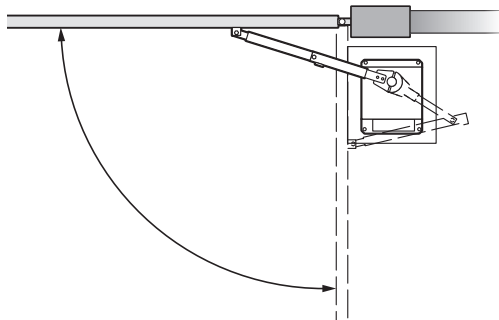

STEP 4

Once satisfied with the installation and movement of the gate, weld the arm pieces securely. Paint the Arm to protect against rusting.

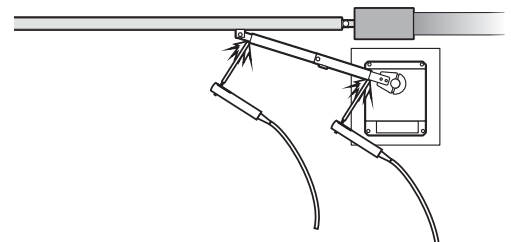

STEP 5

Rotate the Clutch until it lines up with the notches on top of the Output Shaft and insert the Clutch Key.

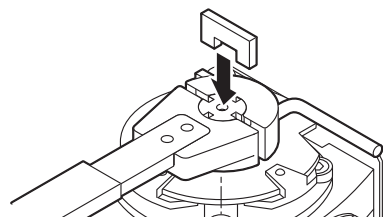

STEP 6

Verify the Clutch is adjusted properly.

- Both sides adjusted **evenly**.
- Handle is locked, **by hand**, and positioned horizontally at 0°.

With the Clutch Key removed, the Clutch should not slip with moderate force applied to the gate.

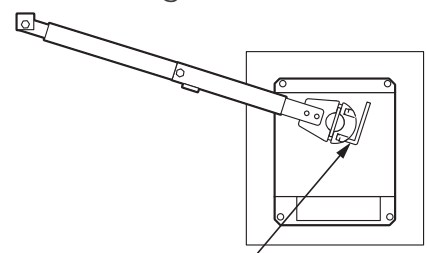

← Tighten the Clutch

ELECTRICAL INSTALLATION

High Voltage Supply Option

⚠ Caution: Always turn off power breakers when working with high voltage. DO NOT connect the “Power Harness” to the Control Board until the electrical installation is complete and ready for verification.

STEP 1

At the “Power Supply Panel”:

- Set the “Voltage Selector” according to the supply voltage (115V or 230V).
- Turn the “AC Power” switch ON

STEP 2

⚠ WARNING: SINGLE PHASE AC ONLY

At the “J-Box”:

- Connect the incoming power wires, matching the wire color codes.
- If the supply voltage is 120VAC, connect the red wire, labeled “Outlet Power”, to the neutral (white) wires.

STEP 3

- Turn ON the main facility breaker
- Verify that all three (3) LEDs are illuminated at the “Power Box”.
- Turn the “Battery Switch” ON.

At the Control Board:

- Connect the Power Harness and verify the “POWER” LED is illuminated solid.

⚠ TECHNICAL TIP: If the “Power” LED is flashing or any of the 3 LEDs on the “Power Box” are not illuminated, refer to the Troubleshooting pages.

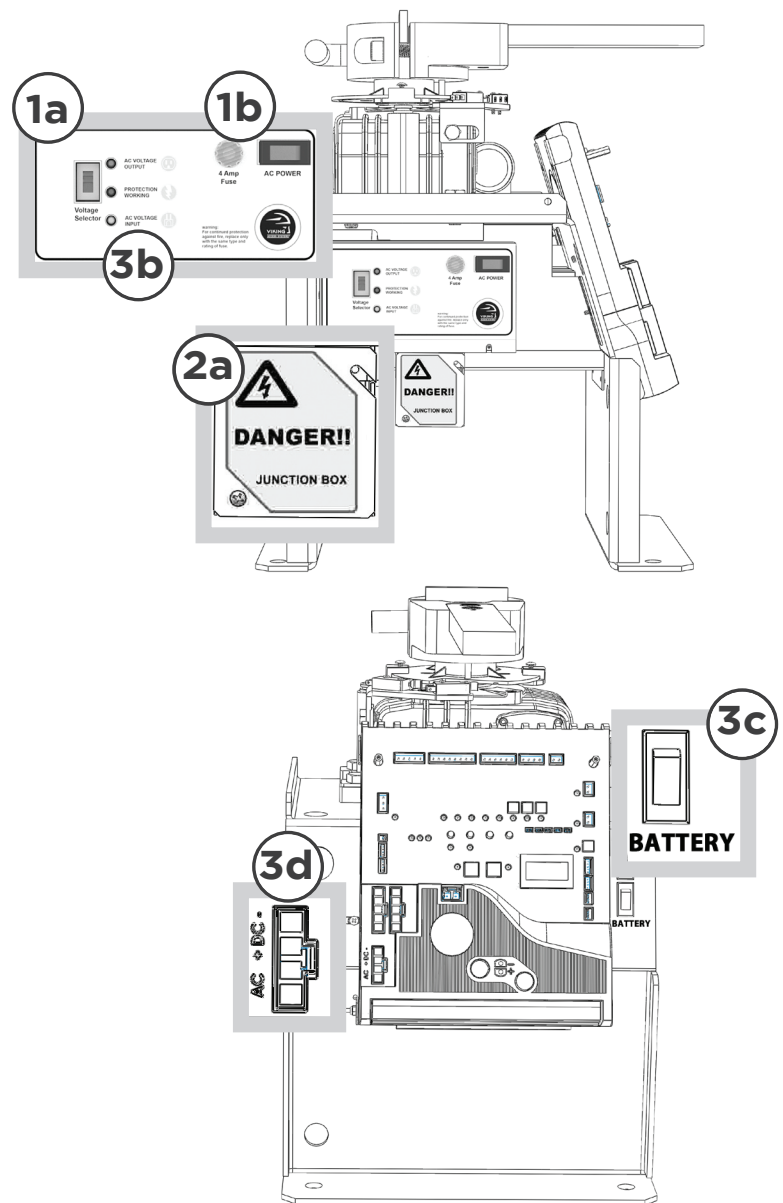

Tips for proper ground installation:

To minimize the effects caused by lightning, follow these guidelines.

- Use a ground rod to provide a ground reference.
- Consult your city code and be aware of under-ground services in the site of the gate operator to prevent inconveniences.
- Always use a single bonding point for grounding.
- All ground wires must be as short and as thick as possible.
- Prevent unnecessary turns or loops in all ground wires.

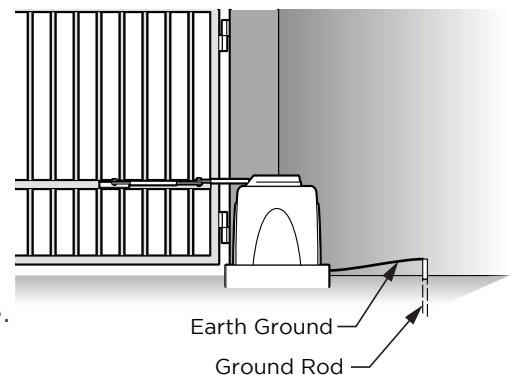

ELECTRICAL INSTALLATION

Low Voltage Supply Option

TIP: As an alternative to high voltage, the operator can be power by 24VAC. It is recommended to use Vikings Modular Power Box (**part # VNXMPB**) as the source.

⚠ Caution: Always turn off power breakers when working with high voltage. DO NOT connect the “Power Harness” to the Control Board until the electrical installation is complete and ready for verification.

Install the “Modular Power Box” at the nearest high voltage source (115V or 230V single phase AC) and connect to the operator Power Harness. Follow local codes or guidelines.

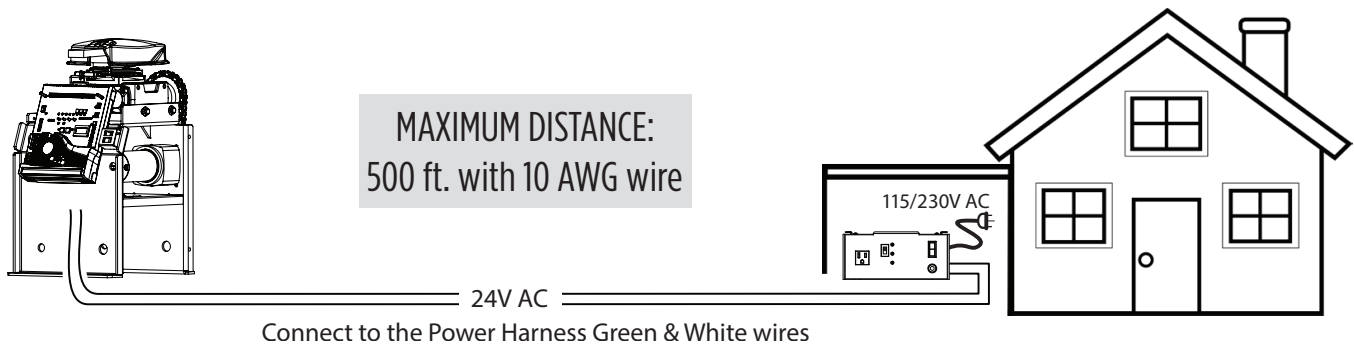

Solar Supply Option

Vikings Solar Package (**part # VA-SOCHP**) is an efficient and effective solution to powering the operator with solar energy. (See page 44 for package details)

⚠ Tip: Solar efficiency can be increased by activating the “Pre-Warning” **(A)** feature. The “Aux. Pwr” **(B)** terminals will provide 24VDC to all nonessential controls, beginning 3 seconds prior to gate movement, until the gate reaches either limit. (page 23)

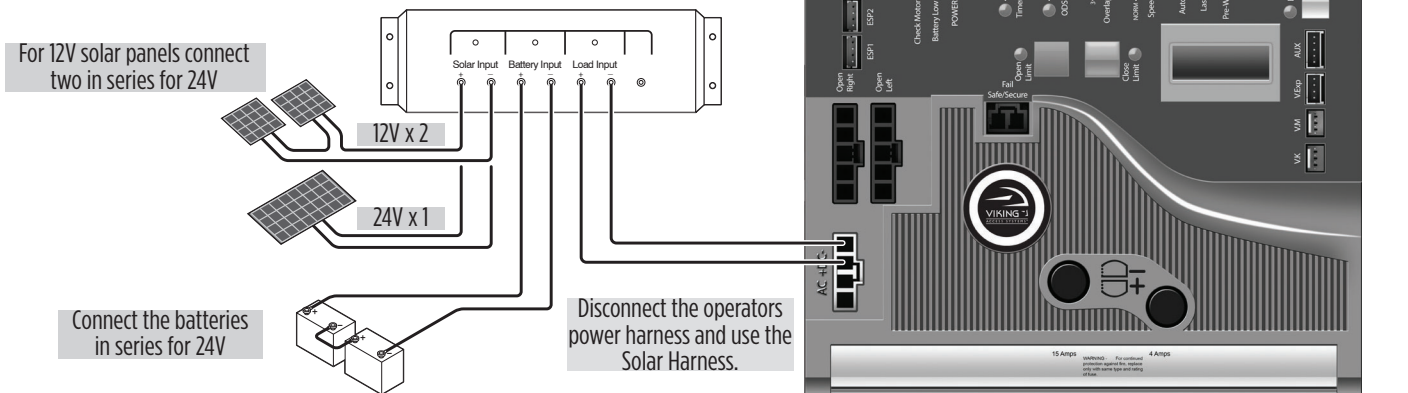

⚠ IMPORTANT: The number of cycles achieved daily is dependent on many factors, including local solar radiation data and power consumption of the motor and accessories. It is very important that you consider this when using solar power.

ELECTRICAL INSTALLATION

MONITORED UL SENSOR CONNECTIONS

UL (Monitored Input Terminal)

The “UL” input terminal protects against entrapment in both the opening and closing directions. Input will reverse the gate momentarily in the opposite direction it was traveling when a connected device it triggered. Pages 6-7.

Re-Open (Monitored Input Terminal)

The “Re-Open” input terminal protects against entrapment in the closing direction ONLY. Input will reverse the gate all the way to the Open Limit when a connected device it triggered. Pages 6-7.

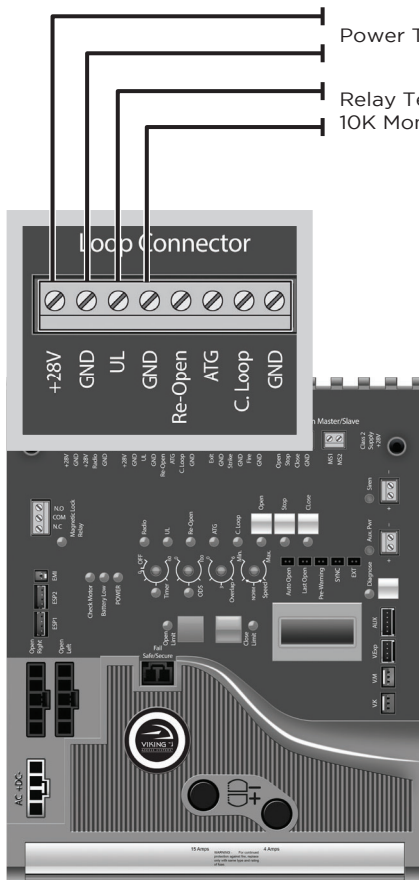

NOTE: The “Stop” LED will be illuminated if there is a failure with at least one monitored entrapment sensor and the gate operator will be rendered inoperable.

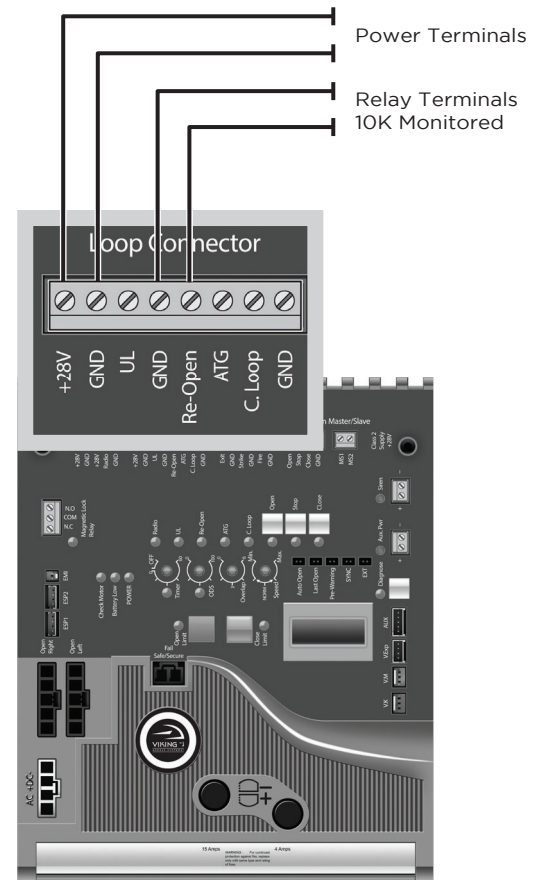

Check for proper operation:

When a connected device is triggered, the “UL” LED will illuminate and, if more than one Monitored device connected, the “Stop” LED will flash rapidly to indicate an input.

⚠ If more than one Monitored device is connected to this terminal, the “UL” LED will be illuminated. This alone is inconsequential.

Check for proper operation:

When a connected device is triggered, the “Re-Open” LED will illuminate and, if more than one Monitored device connected, the “Stop” LED will flash rapidly to indicate an input.

⚠ If more than one Monitored device is connected to this terminal, the “Re-Open” LED will be illuminated. This alone is inconsequential.

⚠ **TECHNICAL TIP:** For more information regarding accessory connections to the Control Board and individual input terminal functions, refer to pages 26-27.

LIMITS SETUP

⚠ IMPORTANT: This gate operator uses mechanical limit switches. Therefore, the limits cannot be set electronically by the Control Board. The Limit Buttons on the Control Board have been rendered inactive.

STEP 1 Connect the “Limit Switch Harness” to the Control Board.

- a. “OPEN RIGHT” Connector if the gate opens Right.
- b. “OPEN LEFT” Connector if the gate opens Left.

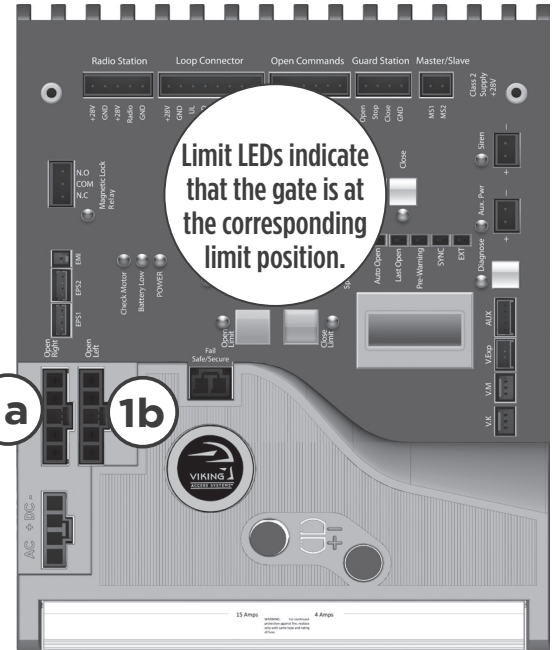
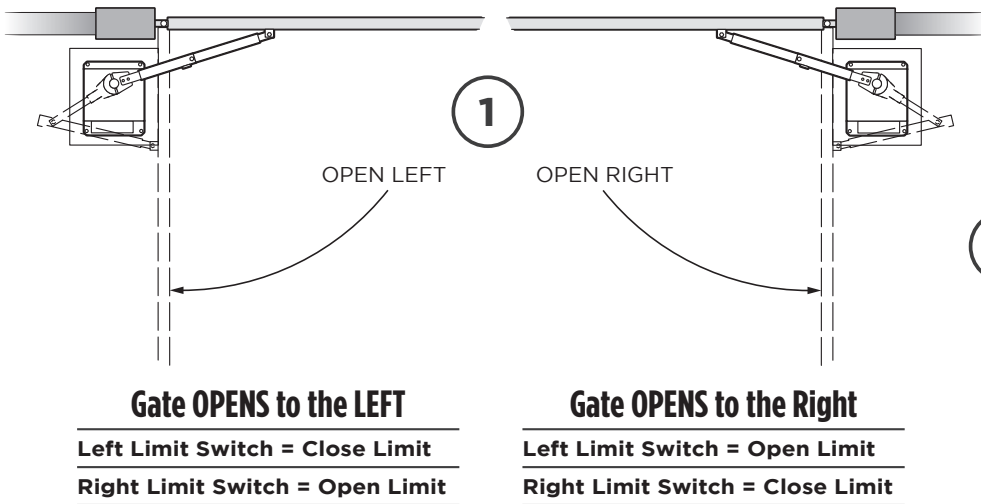

STEP 2

At the “Limit Cam & Holder” assembly:

- a. Loosen screws on both of the “Limit Cams”.
- b. With the Articulating Arm and “Clutch” installed, insure that the “Clutch Guide Pin” is inserted into one of the four holes on the “Cam Holder”.
- c. Move the gate manually to the desired closed limit position and adjust the nearest “Limit Cam” to actuate the corresponding “Limit Switch”.
- d. Slightly tighten the Limit Cam Screws.
- e. Repeat Step 2c & 2d for the desired open limit position.
- f. Run the gate 2 full cycles before confirming your limit settings. Adjust accordingly if required.

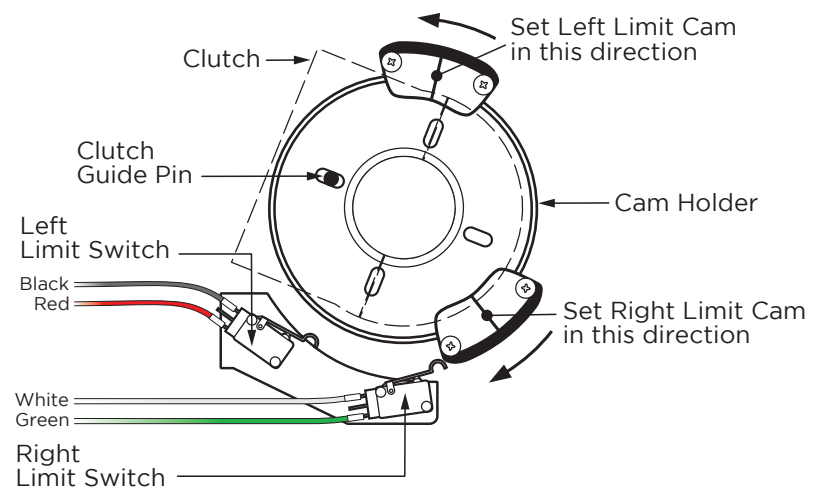

NOTE: Referring to Step 2b. The “Cam Holder” contains four (4) Guide Pin holes for convenience. It is recommended to mark the hole used for future reference if needed.

⚠ TECHNICAL TIP: Each Limit LED will illuminate solid when the corresponding limit switch is actuated. Several LEDs will flash simultaneously when both Limit Switches are actuated at the same time or may indicate a problem with the limit switches or wires.

PRIMARY/SECONDARY SETUP

Two Wire Communication

⚠ IMPORTANT: DO NOT run the Primary/Secondary communication cable in the same conduit or within 12" of 115 - 230V power supply cables.

⚠ Technical Tip: DO NOT set the "Timer" and/or "Overlap" features on both operators Control Boards. Only turn these features on at the Primary Control Board.

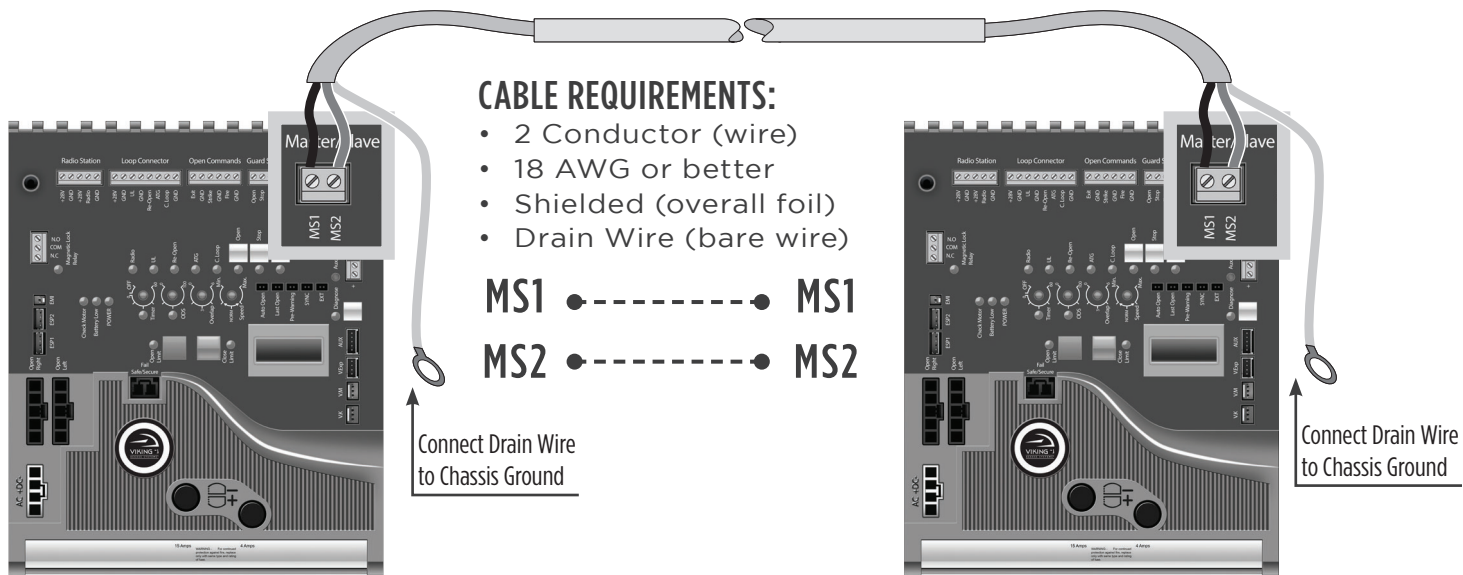

Step 1

Connect shielded cable to "Primary/Secondary" connectors at the control boards

Step 2

At the Primary Operator:

Connect the entrapment protection sensor(s) as described on pages 7 and 18.



Step 3

At the Secondary Operator:

Turn ON the DUAL MODE Feature:

- Toggle the "Diagnose" button until you see DUAL MODE on the LCD Display.
- Default setting is OFF.
- Press and hold the "Stop" button.
- Toggle the "Diagnose" button once.
- The feature should now be displayed as ON.

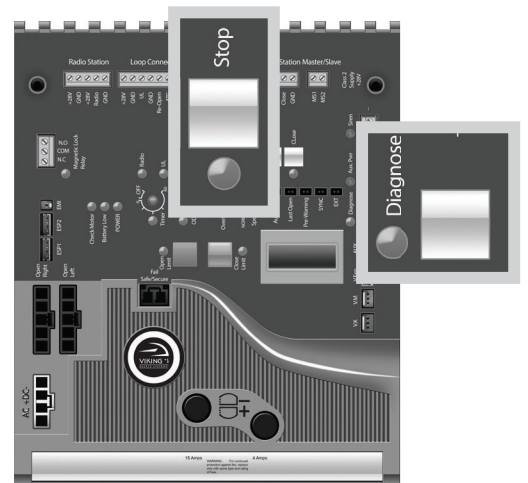

PRIMARY/SECONDARY SETUP

Wireless Communication Options

REQUIRED ADD-ON:

Viking Konnect - Wireless Primary/Secondary Kit **PART# VA-KONNECT-MS**

⚠ Technical Tip: DO NOT set the “Timer” and/or “Overlap” features on both operators Control Boards. Only turn these features on at the Primary Control Board.

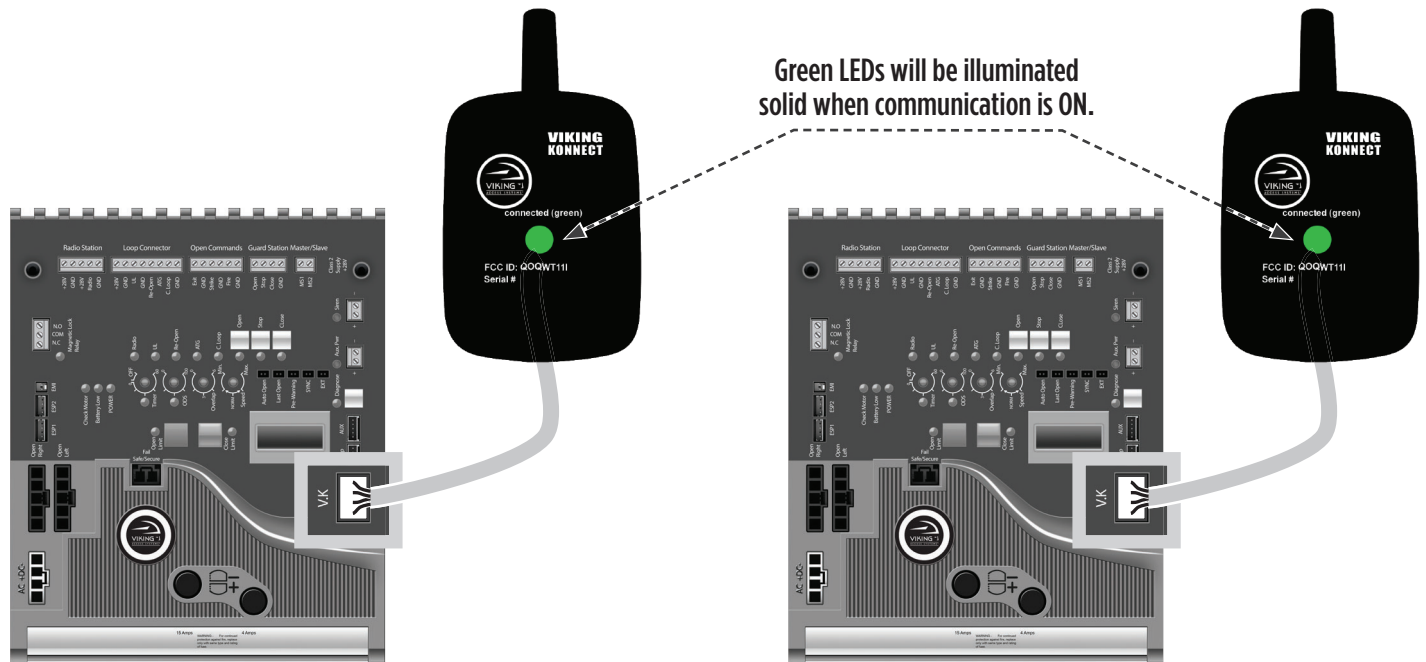

Step 1

Plug the modules on to the “V.K” plug & play connection of each operators Control Board. It is not important which board the Primary or Secondary module is placed on.

Step 2

At the Primary Operator:

Connect the entrapment protection sensor(s) as described on pages 7 and 18.



Step 3

At the Secondary Operator:

Turn ON the DUAL MODE Feature:

- Toggle the “Diagnose” button until you see **DUAL MODE** on the LCD Display.
- Default setting is OFF.
- Press and hold the “Stop” button.
- Toggle the “Diagnose” button once.
- The feature should now be displayed as ON.

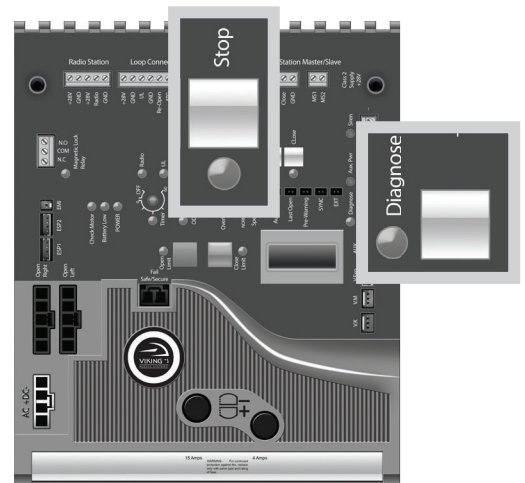

CONTROL BOARD SETUP

Initial Settings

“Speed” Motor Speed

Increases or decreases the speed of gate travel.

“ODS” Obstruction Detection Sensor

Sets the amount of force required to trip the inherent obstruction sensor.

See page 24 for more details about this feature.

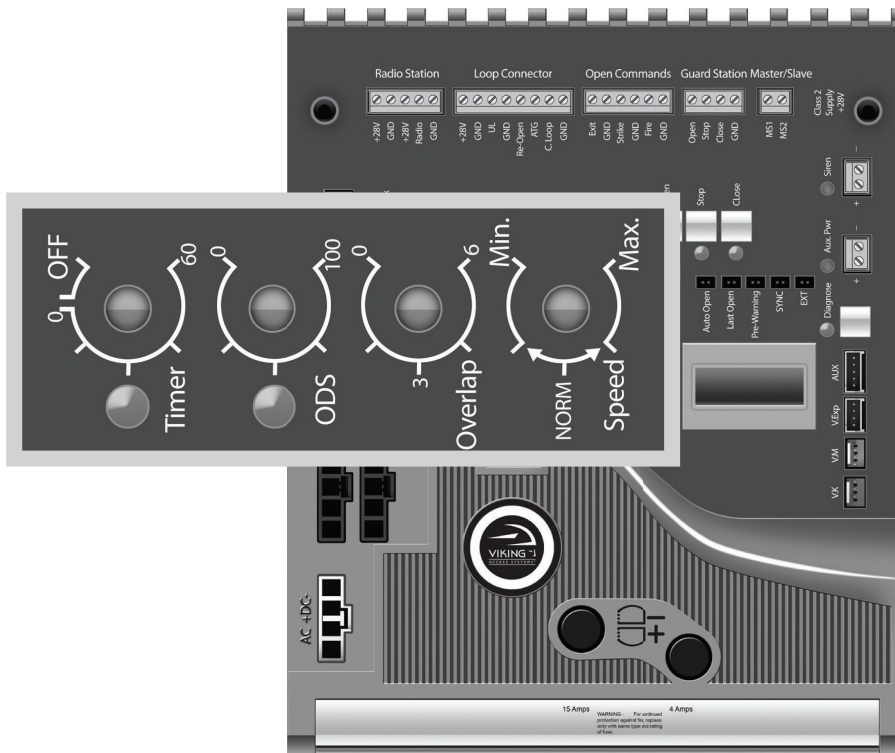

“Overlap” Overlap Delay

Delays the gate from opening for the selected amount of time from 1-6 seconds.

⚠ For Primary/Secondary or dual applications, the Primary will delay to open and the Secondary will delay to close.

“Timer” Hold Open Timer

Automatically closes the gate after the selected amount of time from 1-60 seconds.

Turning the dial between “0” and “OFF” will disable this feature, requiring a close command to close the gate.

CONTROL BOARD SETUP

Initial Settings

NOTE: Installing a shunt, or jumper, on the pins will activate the feature.

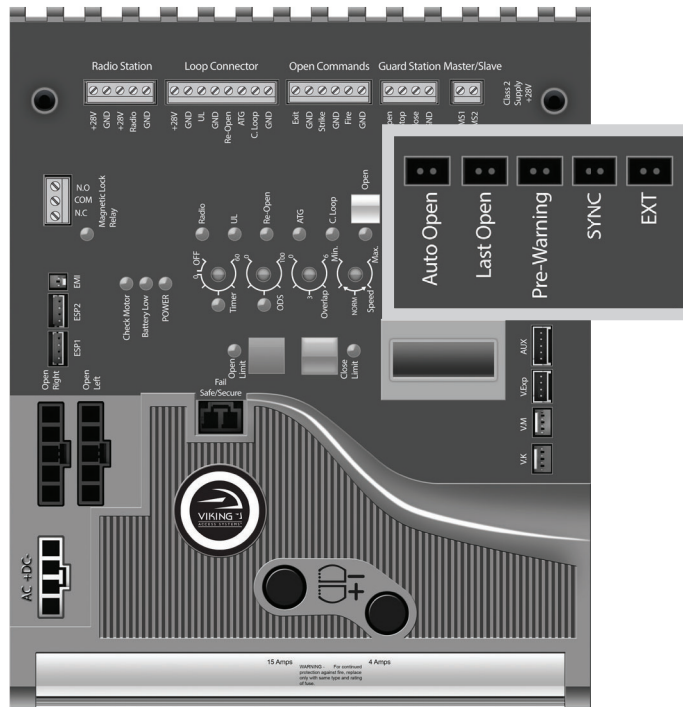

“Auto Open” - Power Failure Option

Opens the gate automatically during power failure. Resumes normal operation when power is restored.

“Last Open” - Power Failure Option

Opens the gate automatically when the battery backup voltage is critically low.

“Pre-Warning” Initiates two options for an audible or visual warning 3 seconds prior to gate motion and will continue:

1. Until gate reaches closed limit:

“Magnetic Lock” terminals provide a contact between “COM” and “N.O.”.

2. Until gate reaches either limit:

“AUX. PWR” terminals provide 24VDC.

“Sync” Used only in conjunction with Barrier Arm Operators. Activating this feature allows for synchronized operation with Barrier Arm Operators. See page 33.

“EXT” Available for future developments.

CONTROL BOARD SETUP

Obstruction Detection Sensor (ODS)

⚠ IMPORTANT: The appropriate “ODS” setting is dependant upon the gate installation and construction. Set this feature accordingly. Additional Safety equipment should be used to reduce possible risk of injury or vehicle damage.

“ODS” Obstruction Detection Sensor

The Obstruction Sensor detects obstructions in the path of the traveling gate. The dial sets the amount of force required to activate the operators inherent obstruction detection.

Setting the dial to “0” will require the least amount of force to activate;

Setting the dial to “100” will require the maximum amount of force to activate.

UL 325 standard requires an audible alarm to go off after two consecutive entrapment events sensed by the Inherent Entrapment Protection of the Gate Operator.

The audible alarm will sound for a period of 5 minutes or until a Stop command or the “Alarm Reset” switch has been actuated. (refer to page 8)

When the Obstruction Sensor detects an obstruction it will:

1. Stop the gate’s movement and reverse it momentarily.
2. Bring the gate to a resting position.
3. Disable the Hold Open Timer feature until the Gate Operator receives a new command.

If second obstruction is detected before the gate reaches either limit it will:

1. Stop the gate’s movement.
2. Disable the Gate Operator.
3. Sound the UL Alarm
4. A STOP command must be provided to disable the alarm and continue operation.

⚠ TECHNICAL TIP: The Status LED for the “ODS” will indicate the following when it has been triggered.

A. **Solid:** Obstruction.

Detected a sudden or abrupt increase in gate resistance.

B. **Flashing:** Overload.

Detected a more subtle, but sustained increase in gate resistance.

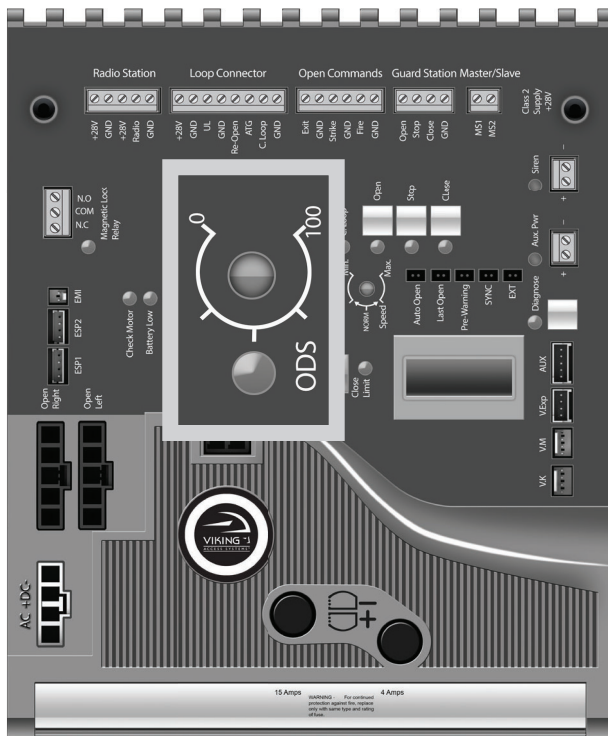

CONTROL BOARD SETUP

Viking Heater

The operator has an integrated heater that is thermostatically controlled. Activate this feature when the operator is used in application temperatures down to -20°F (-29°C).

To set the heater to turn on at the Close Limit:

1. Use the “Diagnose” button to scroll through the LCD Display to “HEATER CLS”
2. Press and hold the “Stop” button on the Control Board.
3. Press and release the “Diagnose” button to turn this feature ON and OFF.

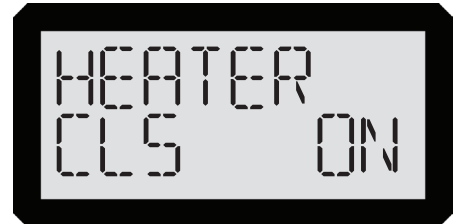

To set the heater to turn on at the Open Limit:

1. Use the “Diagnose” button to scroll through the LCD Display to “HEATER OPN”
2. Perform steps 2-3 as described above.



NOTE: If the application requires the gate to be held open for any reason, set the HEATER ON for both limit positions.

⚠ IMPORTANT: AN EXTERNAL POSITIVE STOP **must** be used on the gate at the limit position(s) the HEATER has been set for.

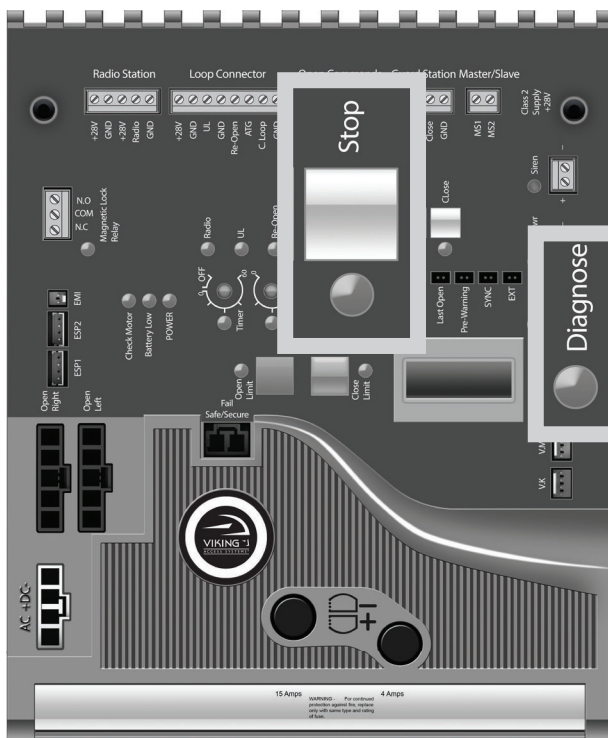

Viking Lock Mode

Turning this feature ON will secure the gate at the closed position, preventing unauthorized manual entry.

Use the LCD Display to activate this feature.

1. Use the “Diagnose” button to scroll through the LCD menu to “LOCK MOD”
2. Press and hold the “Stop” button on the Control Board.
3. Press and release the “Diagnose” button to turn this feature ON and OFF.

ACCESSORY CONNECTIONS

Access Control Connections

Power Connections

The Control Board provides a 24VDC output to power external devices and controls. Alternatively, for devices that require a power supply other than 24VDC, the operators Power Box contains a convenient 120VAC receptacle to connect a plug-in transformer.

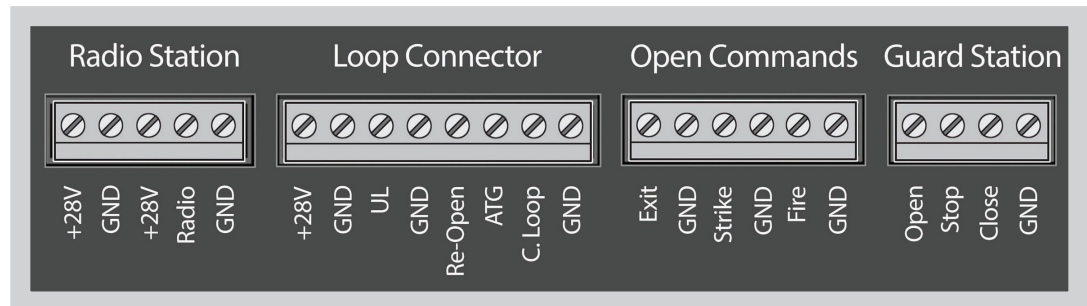

“C” = Common
 “N.O.” = Normally Open

Terminals Connections and Input Functions:

Viking Terminal	Function	Device Terminal
“+28V”	DC Positive	“+”
“GND”	DC Negative	“-”
“GND”	Relay Common	“C”
“Radio”		“N.O.”
	If “Timer” OFF: If “Timer” ON:	Open - Stop - Close Open / Reopen if closing
“UL”	(see pages 6-7 & 18)	“N.O.”
	If stopped: If traveling:	Prevents the gate from moving Stops then reverses gate momentarily
“Re-Open”	(see pages 6-7 & 18)	“N.O.”
	If stopped: If closing:	No function Stops then Opens gate
“ATG” Anti-Tailgate		“N.O.”
	Input is received: Input is released:	Stops gate if closing Closes gate to prevent tailgating
“C. Loop”		“N.O.”
	If not at open limit: If at open limit:	No function Prevents gate from Closing
“Open”, “Exit”, “Fire” & “Strike”		“N.O.”
	If stopped: If closing:	Opens gate Stops then Opens gate
“Stop”		“N.O.”
	If traveling:	Stops gate
“Close”		“N.O.”
	If stopped: If traveling:	Closes gate No function

⚠ TECHNICAL TIP: Each input Terminal (i.e. Radio, Exit, Re-Open, UL) has a corresponding Status LED that when illuminated indicates an input is currently being provided to the terminal and the gate is responding accordingly. (See pages 34-35 LED References)

ACCESSORY CONNECTIONS

Relays In General

NOTE: Viking Access Systems does not provide the external safety devices and access controls. These items can be purchases from your dealer or distributor.

In General

In regards to the Viking Control Board, all external safety devices and access controls contain, and are, simple relays that provide an input to the Viking Control Board when the device is activated.

When these devices are activated, their internal relays create a contact, or short, between the “C” and “N.O.” terminals. This contact is what provides the command to the Viking Control Board.

▲ TECHNICAL TIP: Viking uses the Normally Open “N.O.” contact from the device, excluding “fail-safe” type photo beams. In such instances, the Normally Closed “N.C.” will be used instead.

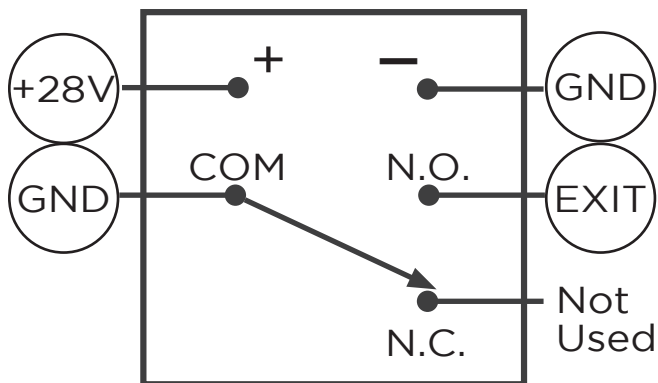

Glossary of Terms

- 1. Terminal:** Wire Connections.
- 2. Input Terminal:** On the Viking Control Board, the terminal which is labeled for a specific command (Re-Open, Exit, Radio, etc.). The N.O. contact from the access control device is to be connected to the Input Terminal.
- 3. Terminal Block:** On the Viking Control Board, a removable block containing multiple terminals.
- 4. Relay:** The component of an access control or safety device that provides an input or command to the Viking Control Board.
- 5. “C” Relay Common Terminal:** This is the relay terminal that makes contact (a short) to the N.O. terminal when the device is activated. *Always wire this relay terminal to any “GND” terminal at the Control Board.*
- 6. “N.O.” Relay Normally Open Terminal:** The relay terminal that has an open contact to “C” while the relay is not activated, and a closed contact when the relay is activated. *Almost always wire this relay terminal to an “Input Terminal” at the Control Board,*
- 7. “N.C.” Relay Normally Closed Terminal:** The relay terminal that has a closed contact to “C” while the relay is not activated, and an open contact when the relay is activated. *This terminal is rarely used.*
- 8. Relay Coil:** Contains the terminals that provide power at the relay.
- 9. “+” Relay Positive Terminal:** The positive power pole for the relay coil. *Always wire this relay terminal to any “+28V” terminal at the Control Board.*
- 10. “-” Relay Negative Terminal:** The negative power pole for the relay coil. *Always wire this relay terminal to any “GND” terminal at the Control Board.*

ACCESSORY CONNECTIONS

Radio Receiver

NOTE: The operator may be supplied with a **FA-XR2C** Radio Receiver and (2) FA-XT4RC Transmitters.

STEP 1

Wire the Radio Receiver as illustrated.

⚠ TECHNICAL TIP: The FA-XR2C Radio Receiver is IP44 rated for water resistance and can be mounted outside of the operator cover if desired.

STEP 2

Program the FA-XT4RC Radio Transmitters to the FA-XR2C Radio Receiver. Follow the instructions provided with the Transmitters.

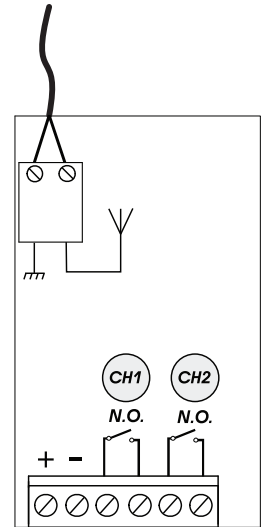
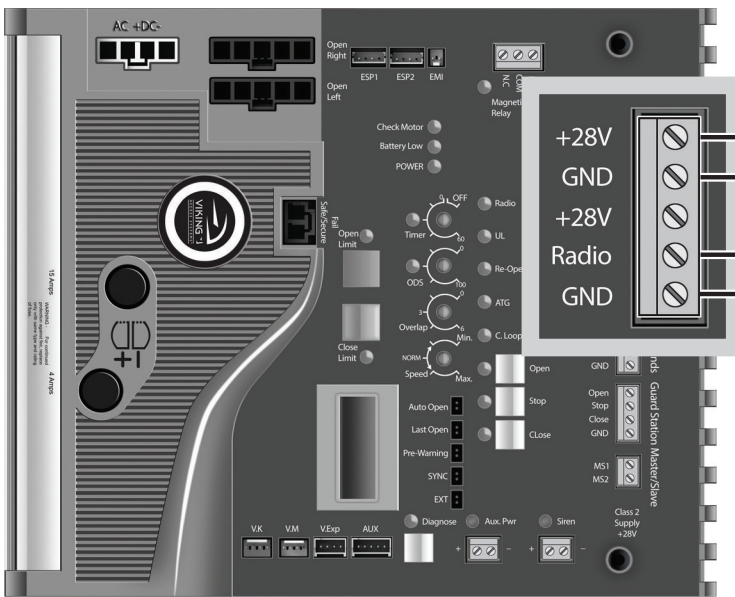

FAAC XR2 Terminals	Wiring Harness	“Radio Station”
+	RED	+28V
-	BLACK	GND
COM	GREEN	GND
N.O.	WHITE	Radio

⚠ TECHNICAL TIP: The Control Board provides two modes of operation that a radio receiver can control the gate. For more information regarding accessory connections and terminal functions, refer to pages 26-27.

1. Open-Stop-Close

By having the radio receiver connected as illustrated and with the “Timer” OFF: This type of configuration is not recommended for commercial installations.

2. Open Only

By having the radio receiver connected as illustrated and with the “Timer” ON.

ACCESSORY CONNECTIONS

Photocell

NOTE: The operator may be equipped with a **FA-XP30-10K** Photocell. Refer to pages 6-7, 18 for UL 325 requirements.

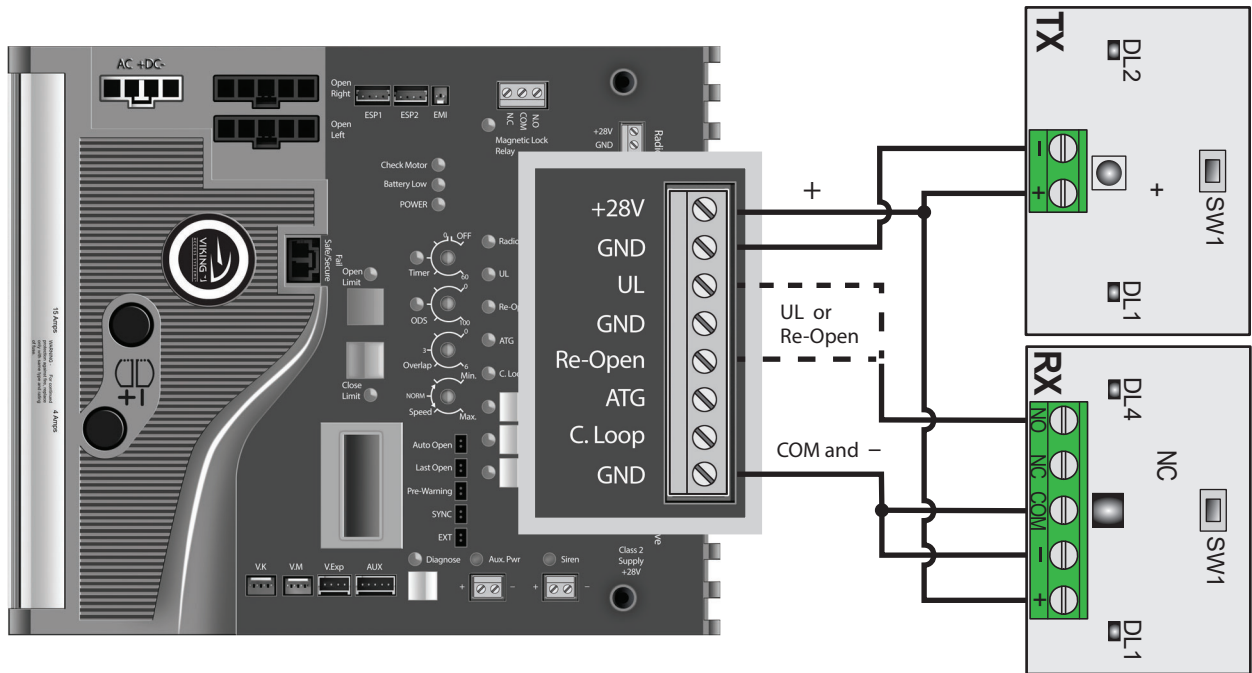

ACCESSORY CONNECTIONS

Viking Loop Rack

TIP: This operator may be equipped with a pre-wired **Loop Rack** that plug-in type loop detectors can be connected to. This provides a convenient alternative to the box type loop detectors that would need to be wired to the Control Board.

Loop Rack: Part # VA-LR

Loop Rack Wiring Harness: Part # VA-LRH

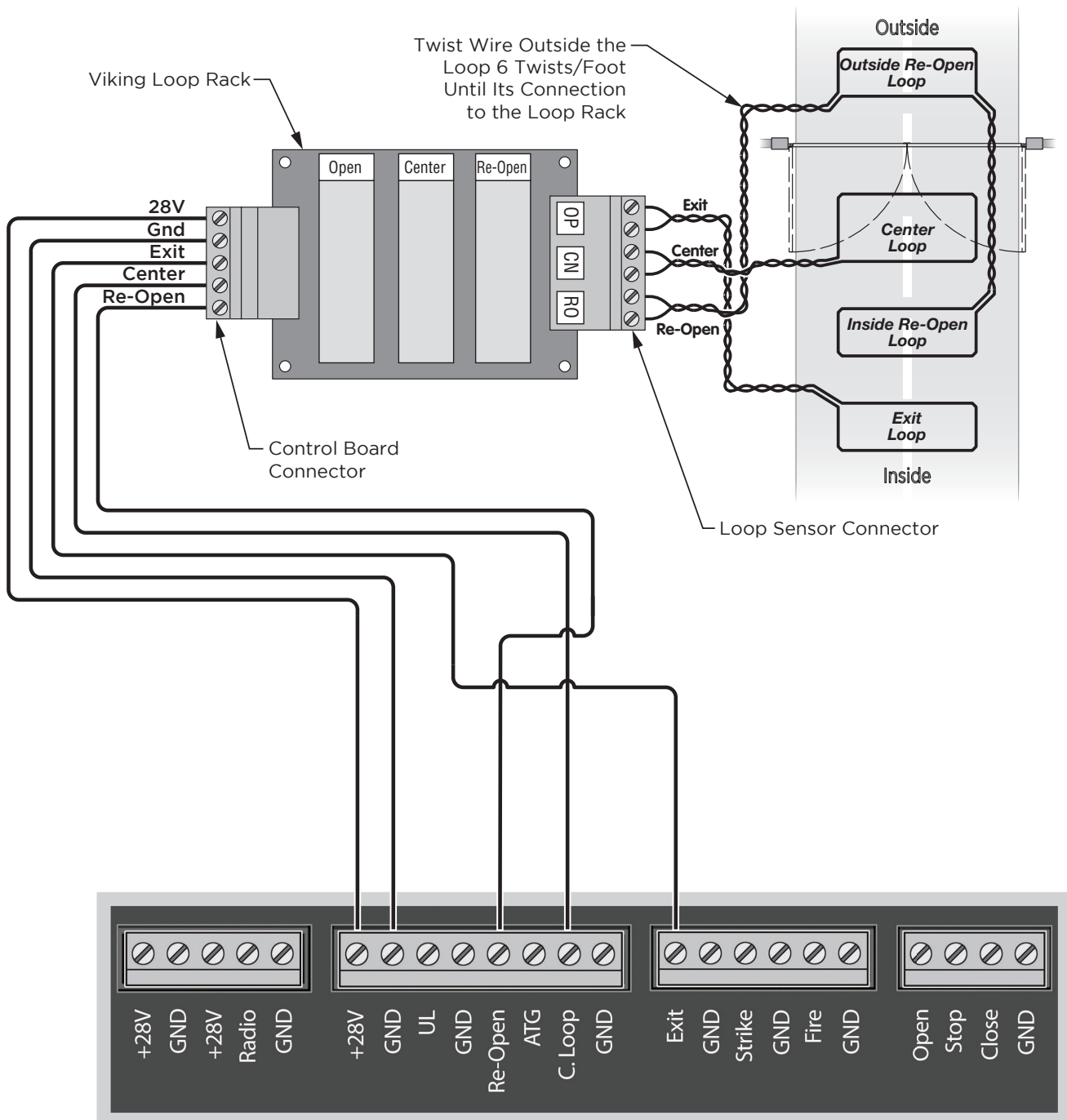

ACCESSORY CONNECTIONS

Guidelines for Loop Installation

1. Prevent sharp corners in the geometry of the loop sensor.
2. Install the appropriate number of turns for your loop geometry based on the loop perimeter. Use the Table below as a guide.
3. Use XLP (cross-linked-polyethylene) type of wire. This wire reduces the effects of moisture and other environmental events in altering the functionality of the vehicular loop detector.
4. Twist the lead wire at least 6 turns per foot.
5. Use BACKER-ROD to minimize damage to the loop detector wire prior to using the sealant.
6. Place the loop detector wire and adjust the sensitivity of the vehicular loop detector unit as needed.

⚠ IMPORTANT! Some of the following parameters may affect the proper functionality of the vehicular loop detector.

Consult the manufacturer of the vehicular loop detector and/or loop wire.

- Gate size
- Number of turns in the loop sensor wire
- Distance of the loop sensor wire to the gate

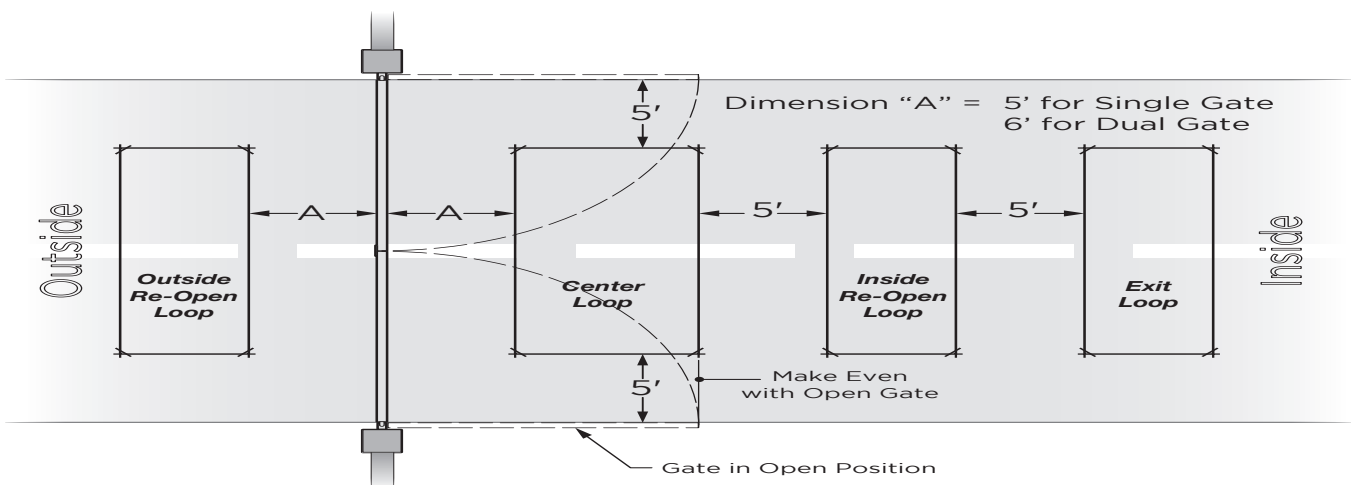
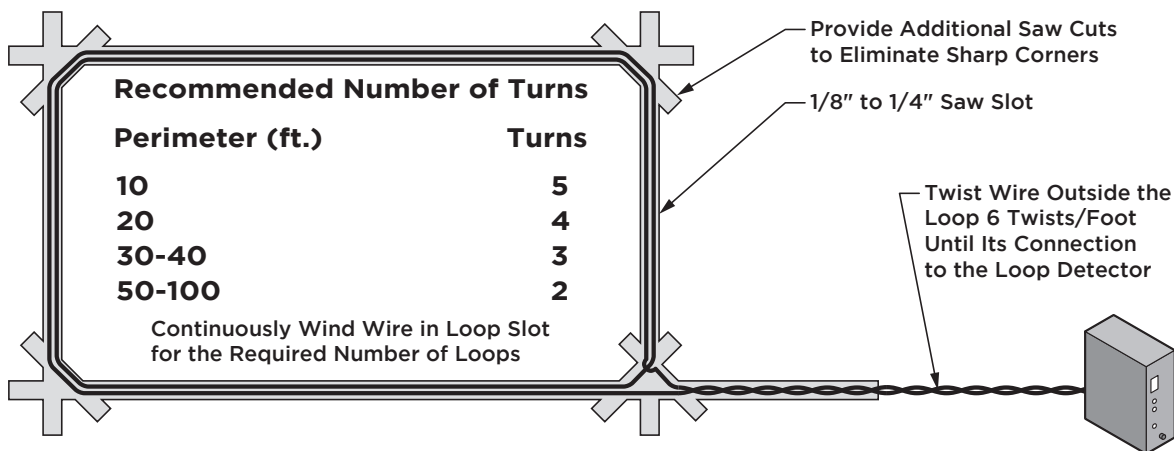
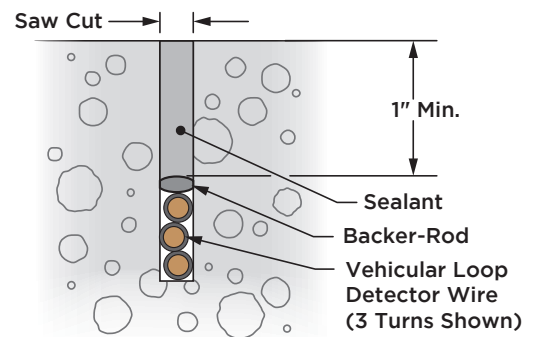

ACCESSORY CONNECTIONS

Magnetic Lock, Lock Solenoid

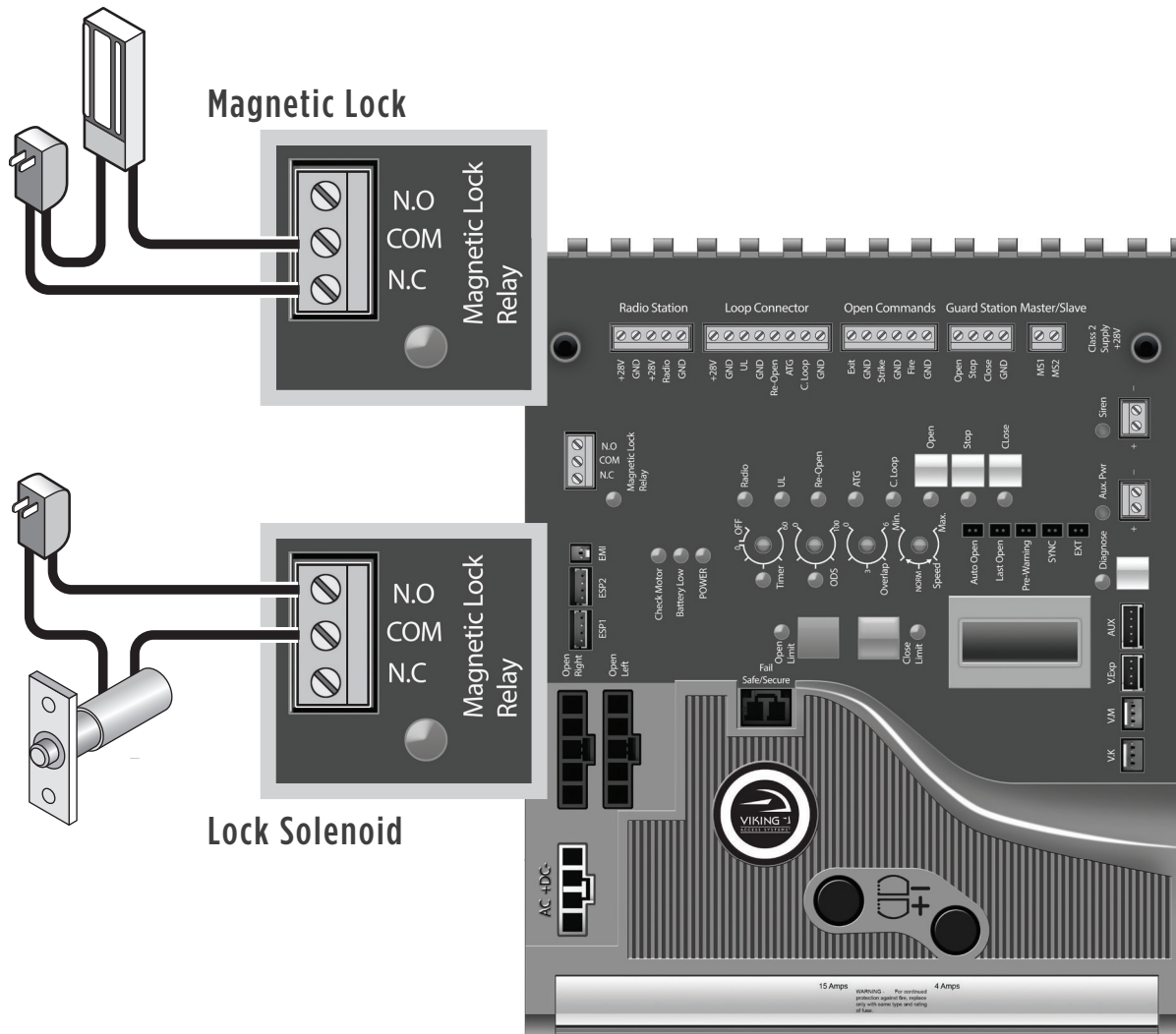

Power for the Locks:

Do not use the 24VDC power supplied by the Control Board. A Class 2 external power supply or plug-in transformer, must be used for the magnetic lock or lock solenoid. This will prevent rapid drainage of the battery in the event of power failure.

The control boards "Magnetic Lock" relay is rated for 10A-250VAC.

⚠ TECHNICAL TIP: The Magnetic Lock Relay LED will indicate status of the on-board relay even if a lock is not connected to the Control Board. Refer to page 34.

ACCESSORY CONNECTIONS

Barrier Arm Synchronization

NOTE: The Control Board provides a convenient solution for applications that require synchronized operation with a Barrier Arm Operator. Consult the Barrier Arm operator's documentation for further instructions.

This type of application opens and closes in the following pattern:

1. Open Command is provided only to the Barrier Arm operator.
2. The Barrier Arm will send an open input to the Viking gate operator; Barrier Arm will delay to open until the Viking gate operator reaches its Open Limit.
3. Barrier Arm will close first; the Viking gate operator will delay to close until the Barrier Arm reaches its Close Limit. Turn the "Timer" on at the Viking Control Board.

STEP 1 (Figure A)

At the Barrier Arm operator, connect the device(s) that will be used as the primary OPEN input.

STEP 2

Connect the Barrier Arms' designated sync output terminals to the Strike input at the Viking gate operator.

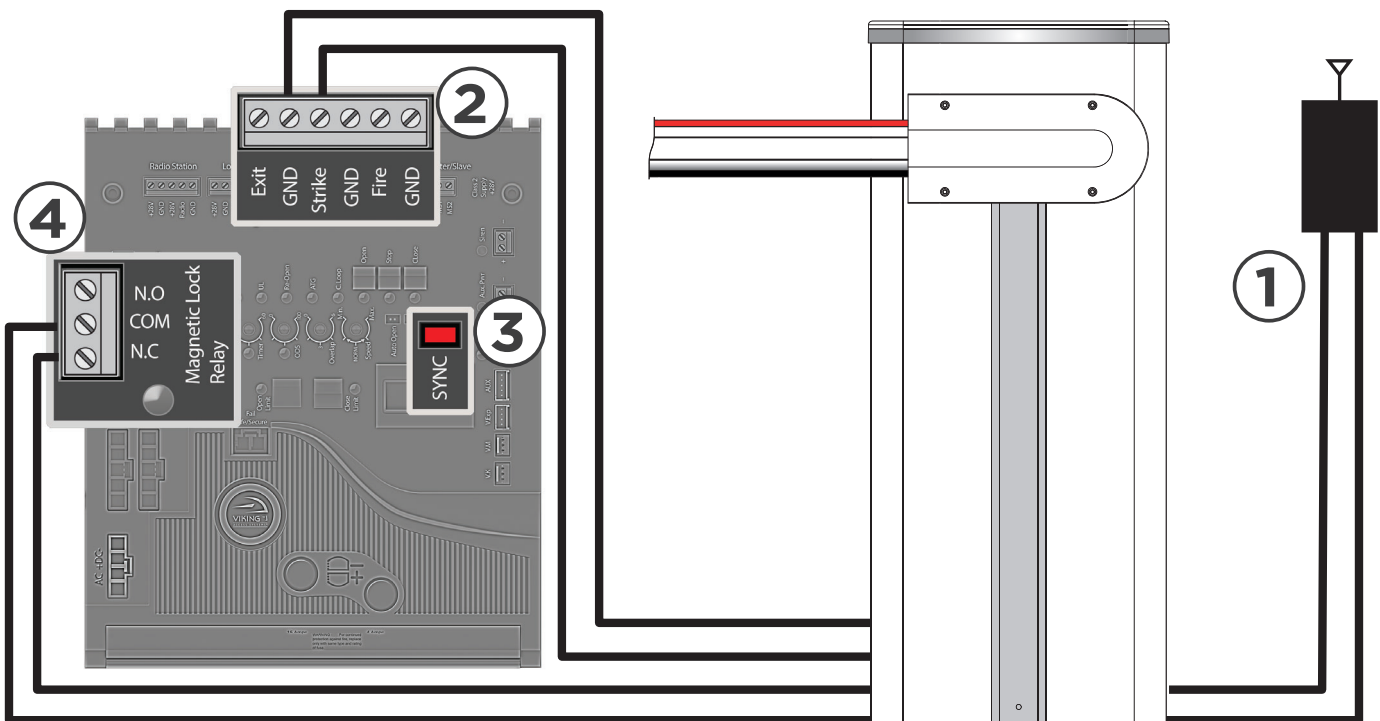

STEP 3

At the Viking gate operator, activate Sync Mode by placing a jumper on to the pin headers labeled "SYNC".

STEP 4

Connect Magnetic Lock relay terminals ("COM" and "N.C.") to the Barrier Arms' designated sync input terminals.

TROUBLESHOOTING

LED References

In addition to the LCD Display, the Control Board LEDs monitor the various circuits of the Control Board. Use the table below to identify the corresponding “TS Ref#” and refer to pages 34-40 for further troubleshooting.

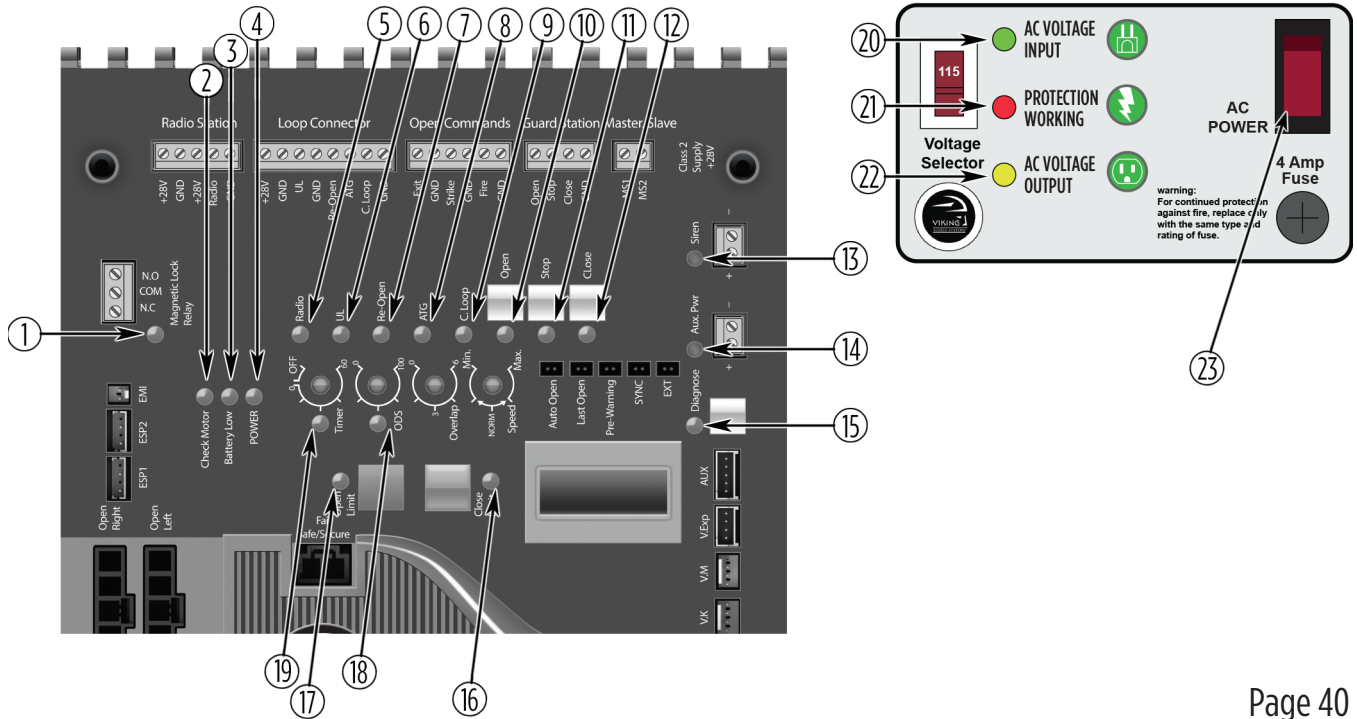

#	LED	Status	Meaning	TS Ref#(s)
1	"Magnetic Lock Relay"	OFF	At Closed Limit and Magnetic Lock Relay state is closed across "COM" & "N.C.". (pg 32). Gate should be at the Close Limit.	
		SOLID	Not at Closed Limit and Magnetic Lock Relay state is closed across "COM" & "N.O.". (pg 32). Gate should not be at the Close Limit	
2	"Check Motor"	OFF	Normal Condition.	
		SOLID	The Control Board is sending power to the motor but the circuit is open.	7, 8
3	"Battery Low"	OFF	Normal Condition.	
		SOLID	Batteries are low. Check power supply to the operator. (pg 16-17).	1, 2, 3, 4
		FLASHING	Batteries critically low. Check power supply to the operator. (pg 16-17).	1, 2, 3, 4
4	"POWER"	SOLID	Normal Condition.	
		FLASHING	Operator is running on batteries only (pg 16-17).	1, 2, 4
		OFF	No power to Control Board.	1, 2, 4, 5
5	"Radio"	OFF	Normal Condition.	
		SOLID	Control Board is receiving an input from a device connected to the Radio terminal (pg 26, 28).	9, 10
6	"UL"	OFF	Normal Condition.	
		SOLID	Control Board is receiving an input from a device connected to the UL terminal or when more than one device is connected (pg 6-7, 18, 26).	9, 10, 16, 20
7	"Re-Open"	OFF	Normal Condition.	
		SOLID	Control Board is receiving an input from a device connected to the Re-Open terminal or when more than one device is connected (pg 6-7, 18, 26, 30).	9, 10, 16, 20
8	"ATG"	OFF	Normal Condition.	
		SOLID	Control Board is receiving an input from a device connected to the ATG terminal (pg 26).	9, 10

TROUBLESHOOTING

LED References

Pg 40
TS Ref#(s)

#	LED	Status	Meaning	
9	"C Loop"	OFF	Normal Condition.	
		SOLID	Control Board is receiving an input from a device connected to the C Loop terminal (pg 26, 30).	9, 10
10	"Open"	OFF	Normal Condition.	
		SOLID	Control board is receiving an input from a device connected to any of the following input terminals: Exit, Fire, Strike or Open (pg 26, 30).	9, 10
11	"STOP"	OFF	Normal Condition.	
		SOLID	Control Board is receiving an input from a device connected to the Stop terminal (pg 26). There is a problem with the required monitored sensor(s) connected to the "UL" and/or "Re-Open" input terminals (pg 6-7, 18)	9, 10 16, 20
12	"Close"	OFF	Normal Condition.	
		SOLID	Control Board is receiving an input from a device connected to the Close terminal (pg 26).	9, 10
13	"Siren"	OFF	Normal Condition.	
		SOLID	Second consecutive obstruction has been detected. (pg 22, 24).	1, 2, 11-13
		FLASHING	Batteries are critically low.	1, 2, 4
14	"Aux. Pwr"	OFF	No voltage output on these terminals at the moment.	
		SOLID	There is 24VDC output on these terminals at the moment.	
15	"Diagnose"	OFF	Normal Condition.	
		FLASHING	Errors have been detected; Check LCD Display for ERR messages (pg 38-39).	
16	"Close Limit"	OFF	Gate is not at the close limit position.	
		SOLID	Gate is at the close limit position.	
		FLASHING	Check for correct operator model number on LCD Display.	6
17	"Open Limit"	OFF	Gate is not at the open limit position.	
		SOLID	Gate is at the open limit position.	
		FLASHING	Check for correct operator model number on LCD Display.	6
18	"ODS"	OFF	Normal Condition.	
		SOLID	Obstruction has been detected. (pg 24).	1, 2, 11,-13
		FLASHING	Overload has been detected. (pg 24).	1, 2, 12-13
19	"Timer"	OFF	If gate is at the open limit, the Timer to close is turned OFF. (pg 22)	
		SOLID	Timer to close is ON and counting down to close the gate. (pg 22)	
		FLASHING	Timer is ON but is not timing out due to a conflicting command. (pg 22)	9, 10
20	"AC VOLTAGE INPUT"	SOLID	Normal Condition.	
		OFF	Incoming power to Power Supply Panel Assembly is not sufficient.(pg 16).	1
21	"PROTECTION WORKING"	SOLID	Normal Condition.	
		OFF	EMI Board is damaged and circuit is not protected . Replace EMI Board.	
22	"AC VOLTAGE OUTPUT"	SOLID	Normal Condition.	
		OFF	There is no output voltage from the Power Supply Panel Assembly.	2
23	"AC POWER"	SOLID	Normal Condition for High Voltage installations.	
		OFF	High Voltage is not supplied to the Modular Power Box (pg 16).	1

TROUBLESHOOTING

LCD Display References

The Control Board is equipped with a LCD Display that provides operator information, current conditions, settings, diagnostics and error messages. Use the table below to identify the corresponding “TS Ref#” and refer to pages 34-40 for further troubleshooting.

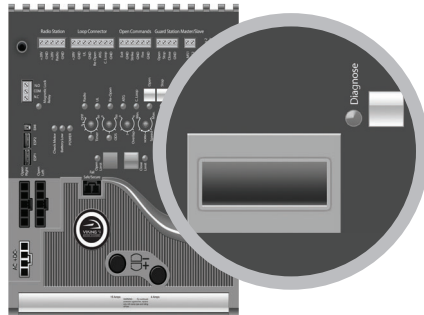

Press the Diagnose button to manually scroll through all of the Messages.

NOTE: Error Messages will be displayed first. The “Diagnose” LED will flash consecutively indicating how many Error Messages are available.

Page 40
TS Ref #s

LCD MSG	Meaning	
MODEL R-6	Indicates the Model of the unit	6

System Status Messages

GATE IS IDLE	Gate is stopped between limits	
GATE IS OPENING	Gate is opening	
GATE IS CLOSING	Gate is closing	
GATE IS OPENED	Gate is at the limit open position	
GATE IS CLOSED	Gate is at the limit close position	
STOP BY OBSTRUCT	Gate has stopped due to an obstruction of the gate system. Also refer to the “ODS” LED. (pg 22, 24, 34 @ #4, 35 @ #18)	11, 12, 13
STOP BY OVERLOAD	Gate has stopped due to an overload of the gate system. Also refer to the “ODS” LED. (pg 22, 24, 34 @ #4, 35 @ #18)	11, 12
OVERLAP TIMING	Gate is waiting for the overlap time	
HOLDING ... SEC	Gate is at the limit open position and timing to close - The display shows the actual time left before closing	10
RED CONN UNPLUGED	The Motor Connector is not plugged into the red Open Left or Open Right socket at the Control Board. (pg 19)	21

LCD MSG Meaning

Multi Meter Displays

MOT AMP
---- A This is the motor current amperage during operation. At Idle, should be 0.0 A.

MOT VOLT
---- VDC This is the actual motor voltage during operation. At Idle, should be 0.0 VDC.

AC VOLT
---- VAC This is the actual low voltage AC to the Control Board from the transformer

CHARGE
---- VDC Indicates the charging voltage to the batteries, With the Battery Switch in the OFF position, should be between 26.0 - 28.0 VDC.

BAT VOLT
---- VDC Indicates battery voltage, if the AC power is discontinued to the Control Board.

Board Settings Messages

SPEED
-- % Shows the percentage of speed set by the Speed adjustment on the Control Board. (pg 22)

OVERLAP
-- SEC Shows the number of seconds set by the Overlap Adjustment on the control board.
This feature is not available on slide gate operator models

OBS SENS
----% Shows the force setting selected to trip the obstruction sensor. (pg 22, 24)

TIMER
-- SEC Shows the amount time set or remaining to hold the gate at the Open Limit position, before the gate starts to close. (pg 22)

HEATER
---- OFF The Integrated Heater is disabled for the open "OPN" and/or close "CLS" limits (pg 25)

HEATER
---- ON The Integrated Heater has been enabled to turn on at the open "OPN" and/or close "CLS" limits (pg 25) "ACTV" will also be displayed while it is heating.

LOCK MOD
---- The Lock Mode feature is turned ON or OFF (pg 25)

UL LEARN
UL_ RD_ Indicates the number of connected Monitored Entrapment Protection Sensors that are being monitored. NO LEARN = no sensors learned. (pg 6-7, 18)

20

TROUBLESHOOTING

LCD Display References

Page 40
TS Ref #s

LCD MSG	Meaning	
Error Messages		
ERR AC LOW	Indicates that the 24VAC supply to the VFlex Board is too low from the 115/230 power supply.	1, 3, 19
ERR AC HIGH	Indicates that the 24VAC supply to the VFlex Board is too high from the 115/230 power supply.	1, 3, 19
ERR AC NO AC	Indicates that there is no 24VAC supply detected to the VFlex Board from the 115/230 power supply.	1, 2, 4, 19
ERR CHRG HIGH	Potential problem with the charging voltage from the Control Board.	1, ?
ERR CHRG CHECK 4A	a) 4 Amp Fuse is blown at the Control Board or; b) There is a problem with the batteries or the Control Board.	18, ?
ERR BAT LOW	The voltage from the batteries is low.	1-4, 18, 19
ERR FUSE 15 AMP	15 Amp motor fuse is blown.	7, 11, 12
ERR LIMIT OPN+CLS	There is a problem with the Limit Switches or Wires.	22
ERR EMI NO EMI	No EMI board detected.	15
ERR EMI NO FUSE	4 Amp main fuse is blown on Power Supply Panel Assembly.	2
ERR EMI NO AC	There is no AC voltage detected at the Power Supply Panel Assembly.	1, 4, 15
ERR EMI UNKNOWN	There is a problem with the communication between the EMI Board and the VFlex Board.	15
ERR EMI PROTECT	Lightning strike protection for the EMI Board (behind the Power Supply Panel Assembly) needs to be replaced	?
ERR REFV WRONG	One, or more, of the Control Board internal reference voltages are incorrect.	?
ERR SENS UL RO	There is a problem with the required monitored sensor(s) connected to the "UL" and/or "Re-Open" input terminals (pg 6-7, 18).	20

(THIS PAGE LEFT BLANK INTENTIONALLY)

TROUBLESHOOTING

Solutions

Begin the troubleshooting process by referring to the error messages on the LCD Display and/or the Status LEDs on the Control Board. Use pages 34-39 to identify the Troubleshooting Reference # (TS Ref#) then reference the table below.

TS Ref#	CHECK	Page Ref#
1	Check that the high voltage power supplied to “J-Box” is within range. 100V-120V or 200V-240V	pg 16-17
2	At the Power Supply Panel Assembly, remove and check 4A Fuse for continuity.	pg 16-17
3	Check that the “Voltage Selector”, on the Power Supply Panel Assembly, is set according to the high voltage power supply. 115VAC or 230VAC	pg 16-17
4	Check the main power breaker and “AC POWER” switch (if applicable) are on.	pg 16-17
5	Check that the Power Harness is connected to the Control Board.	pg 11, 16-17
6	Perform a soft reset by momentarily actuating both limit switches simultaneously.	pg 19
7	Check Motor Fuse on the Control Board.	pg 11
8	Check for an open circuit to the Motor and that the operator is not in Manual Release mode.	pg 7, 10
9	Check the Status LEDs and LCD Display to determine if the Control Board is receiving an input from any external devices or if the “ODS” has been triggered.	pg 22, 24, 34-36
10	Remove the external devices from the Control Board to determine if the Control Board is responding to an input or problem with the external device or wiring.	pg 26-30, 34-35
11	Check the “ODS” setting on the Control Board.	pg 4, 22, 24
12	Check that the gate can be moved manually with low resistance throughout its full length of travel. Check gate track rollers, chain and hinges as applicable.	pg 4, 7
13	Check the limit position.	pg 19
14	Not applicable to this model.	
15	Check the EMI Cable and contacts between the EMI Board and the VFlex Board.	pg 11
16	Check that the LCD Display for Error Messages	pg 38, 39
17	Not applicable to this model.	
18	Check 4 Amp fuse on the Control Board	pg 11
19	Check for 24VAC out from the Toroidal Transformer and Power Harness.	pg 16-17
20	Check the required entrapment protection sensors. Execute the UL Learn Sensor process.	pg 3, 6-7, 18
21	Check that the Motor Harness Connector is connected to the Control Board.	pg 11, 19
22	Check the Limit Switches and Wires. Both limit circuits are to be N.C.	pg 19
23	Not applicable to this model.	
24	Not applicable to this model.	
25	Not applicable to this model.	
26	Not applicable to this model.	
?	Call Viking Technical Support for further assistance.	

PARTS DIAGRAM:

Item	Description	Part No.
1	Operator Cover Bolt (4)	VASWCB
2	Operator Cover	VAR6C020
3	Output Shaft Knob	DWOUK10
4	Output Shaft Cover	DWOC20
5	Clutch Key	VAWRCK20
6	Clutch and Handle	DWCL20
7	Output Arm	DWAR20
8	Output Shaft	R60PS20
9	Limit Cam & Holder	DWLC10B
10	Limit Switch (2)	DULS10
11	Limit Switch Holder	R6LH10
12	Control Board	VFLEXPCBU18
13	Fuse - 15 amp	VNXF15A
14	Fuse - 4 amp	VNXF4A
15	Worm Gear #60 Ratio 30:1	R6GB60K
16	Alarm	DUAL10
17	Toroid Transformer - 10 amp	DUTT10
18	Battery	DUBB12
19	Motor Switch	DUMRS10
20	Battery Switch	DUMRS10
21	Chassis	VNXR6CH
22	Sprocket (Gearbox)	VASPI034
23	Chain #40x38 Pitches	R6CHN40
24	Sprocket (Motor)	VASPI058
25	24V DC Gearhead Motor	VAR6MO
26	Brush Kit	VAMBK
27	120V Receptacle	VA120PL
28	Power Supply Panel Assembly	VNXR6PSPA
29	Main Power Switch	DUMRS10
30	Power Harness	VNXR6PH
31	Limit Switch Harness	VNXR6LSH
32	Multi-Part Arm Assembly	VA-FIARM20

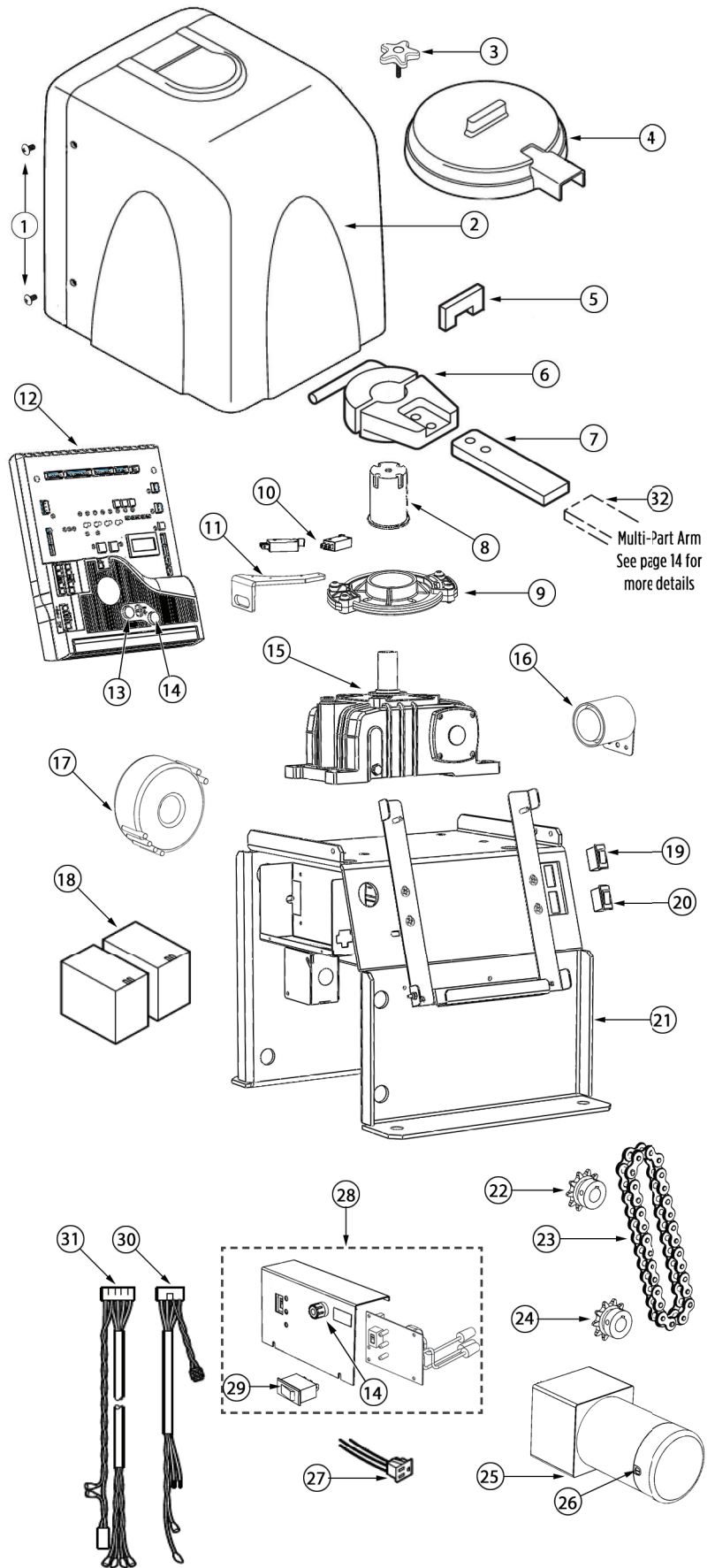

LIMITED WARRANTY

FAAC International, Inc. (“Seller”) warrants the first Purchaser of the product to be free from defects in material and workmanship for a specific period as defined by the Warranty Disclosure on the website www.vikingaccess.com. The Warranty Period commences from the date of invoice.

Control Boards, Accessories or Spare Parts factory installed or sold with any of the products above carry the same warranty period as the product they are sold with, excluding batteries that carry a maximum 2 year warranty.

Accessories or spare parts sold separately have a 1-year warranty period.

Products repaired under warranty carry the remainder of the original warranty period. For products repaired outside of warranty, the Seller warrants that all parts used for the repair will be free from defects in materials and workmanship for a period of ninety (90) days.

Defective products must be returned to Seller, freight prepaid by Purchaser, within the warranty period. A Return Material Authorization Number (RMA) must be obtained before product is returned. Items returned will be repaired or replaced, at Seller’s option, upon an examination which discloses to the satisfaction of the Seller that the item is defective. The Seller will return the warranted item freight prepaid.

This limited Warranty covers the product under the normal use and service for which it was intended, provided it has been properly installed and operated. Seller’s obligations under this warranty shall be limited to the repair or exchange of any part. This warranty shall not apply to products or parts thereof which have been repaired or altered, without Seller’s written consent, outside of Seller’s workshop or altered in any way so as, in the judgment of Seller, to affect adversely the stability or reliability of the product(s) or has been subject of misuse, negligence, or accident, or has not been operated in accordance with the product’s instructions or has been operated under conditions more severe than, or otherwise exceeding, those set forth in the specifications for such product(s).

When the warranty service involves the exchange of an operator or part, the item the Seller replaces becomes its property and the replacement becomes Purchaser’s property. The Purchaser represents that all removed items are genuine and unaltered. The replacement may not be new but will be in good working order and at least functionally equivalent to the item replaced. The replacement assumes the warranty service status of the replaced item.

The products are not warranted to meet the specific requirements, if any, of safety codes of any particular state, municipality, or other jurisdiction, and the Seller doesn’t assume any risk or liability whatsoever resulting from the use thereof, whether used singly or in combination with other machines or apparatus.

The Seller does not assume nor authorizes any person to assume for them any other liability in connection with the sale or use of the products of beyond that extended herein.

The warranty hereinabove set forth shall not be deemed to cover maintenance parts, including, but not limited to hydraulic oil, motor brushes, or the like. No agreement to replace or repair shall constitute an admission by the Seller of any legal responsibility to effect such replacement to make such repair, or otherwise.

All products sold by the Seller are subject to design and/or appearance modifications, which are production standards at the time of shipment. The Seller may, but shall not be required to, modify or update products shipped prior to a current production standard.

THIS WARRANTY IS EXPRESSLY IN LIEU OF ALL OTHER WARRANTIES EXPRESSED OR IMPLIED INCLUDING THE WARRANTIES OF MERCHANTABILITY AND FITNESS FOR USE. THIS WARRANTY SHALL NOT APPLY TO PRODUCTS OR ANY PART THEREOF WHICH HAVE BEEN SUBJECT TO ACCIDENT, NEGLIGENCE, ALTERATION, ABUSE, OR MISUSE OR IF DAMAGE WAS DUE TO IMPROPER INSTALLATION OR USE OF IMPROPER POWER SOURCE, OR IF DAMAGE WAS CAUSED BY FIRE, FLOOD, LIGHTNING, ELECTRICAL POWER SURGE, EXPLOSION, WIND STORM, HAIL, AIRCRAFT OR VEHICLES, VANDALISM, RIOT OR CIVIL COMMOTION, OR ACTS OF GOD.

The Seller shall not be liable for any loss or damage whatsoever resulting, directly or indirectly, from the use or loss of use of the product(s). Without limiting the foregoing, this exclusion from liability embraces a Purchaser's expenses for downtime or for making up downtime, lost profit, damages for which the Purchaser may be liable to other persons, damage to property, and injury to or death of any persons.

This limited warranty extends only to wholesale customers who buy directly through the Seller's normal distribution channels. The Seller does not warrant its products to end consumers. Consumers must inquire from their selling dealer as to the nature and extent of that dealer's warranty, if any.

THE LIMITED WARRANTY OFFERED HEREIN IS THE SOLE AND EXCLUSIVE REMEDY AVAILABLE TO THE PURCHASER. CORRECTION OF DEFECTS, IN THE MANNER AND FOR THE PERIOD OF TIME DESCRIBED HEREIN, SHALL CONSTITUTE THE COMPLETE FULFILLMENT OF ALL LIABILITIES OF SELLER TO THE PURCHASER WITH RESPECT TO THE COVERED PRODUCT, AND SHALL CONSTITUTE FULL SATISFACTION OF ALL CLAIMS, WHETHER BASED ON CONTRACT, NEGLIGENCE, STRICT LIABILITY OR OTHERWISE. IN NO EVENT SHALL SELLER BE LIABLE FOR ANY LOSS OF PROFITS OR ANY INDIRECT, CONSEQUENTIAL, INCIDENTAL, SPECIAL OR PUNITIVE DAMAGES ARISING OUT OF SELLER'S BREACH OF THIS LIMITED WARRANTY, OR ARISING OUT OF THE CUSTOMER'S INABILITY TO USE THE COVERED PRODUCT, EVEN IF SELLER HAS BEEN ADVISED OF THE POSSIBILITY OF SUCH DAMAGES.

Some states do not allow the exclusion or limitation of incidental or consequential damages, so the above limitation may not apply to a particular Purchaser. This Limited Warranty gives the Purchaser specific legal rights. The Purchaser may also have other rights, which vary from state to state.

VIKING EXPANSION PRODUCTS



VIKING KONNECT Primary/Secondary Kit Secure and reliable Primary/Secondary communication between two single gate operators or ECU's using Viking's Konnect technology.

Part# VA-KONNECT-MS

****Q-7 & ECU Operators require (2) Antenna Extension Cables (part# VA-RPSMA)****

**** NOT COMPATIBLE for Solar Mode setting on Control Board (if applicable)****



VIKING MONITOR Off-site access to operator diagnostics. With the Viking Monitor App, this tool allows you to monitor and label multiple operators by site and location for quick reference. Provides error notifications, operator status, settings and diagnostic information.

Part# VA-MONITOR

****Q-7 & ECU Operators require (1) Antenna Extension Cable (part# VA-RPSMA)****



VIKING AC SURGE PRO Adds another layer of protection to the high voltage power supply of your gate operator. Connecting the AC Surge Pro in parallel to the EMI Board, provides a dual layer of protection from surges up to 20,000 Volts / 10,000 Amps. **Part# VA-SURGEPROAC**



VIKING 24V SOLAR KIT The components included in this package are intended to provide sufficient power for general applications.

Part# VA-SOCHP

This Kit includes the following components:

- | | | |
|------------|-----------------------------|---|
| (2) | 12V 40W Solar Panels | Part# VA-S040W (wired in series = 24V 80W) |
| (2) | 12V 35Ah batteries | Part# DUBA35 (wired in series = 24V 35Ah) |
| (1) | Solar Charger | Part# SOCHR10 |
| (1) | Solar Power Harness | Part# SOHAR |

⚠ NOTE: The number of cycles achieved from this kit are dependent upon the following and may require increased panel and battery capacities:

- Power consumption of all accessories being used
- Average solar radiation of geographic location

OUR CONTINUOUS COMMITMENT TO EXCELLENCE

Viking Access Systems is continuously working hard to identify and design products that will appeal to the industry and its needs. As technology continues to advance, we have developed a completely efficient and intelligent line of gate operators to meet the changing demands. These machines offer: full UL325 and UL991 compliance, soft-start and soft-stop, intelligent obstruction sensors, continuous operation (100% duty cycle) and extreme power efficiency. Innovative features include: adaptive and self-learning algorithms, redundancy design in both hardware and software to ensure operation and functionality, protection from lightning, short circuit and power surges, and our exclusive helical gearing offering the highest efficiency rating in the industry. Our entire product line is continually modified and improved based on the latest technology and our customer's valuable feedback. The results are products that offer accuracy, efficiency, reliability and performance, all in sleek, high-tech designs.

We pledge to continue establishing ourself as the leader in high quality, innovative gate operators by developing "Next Level" technology. We are committed to providing safety and convenience with innovative solutions for every security gate need.



VIKING ACCESS SYSTEMS™

VIKING ACCESS SYSTEMS™

VIKING ACCESS SYSTEMS™

INSTALLATION DATE: _____

COMPANY / INSTALLER: _____

CONTACT: _____

SERIAL NUMBER(S): _____

ALL INSTALLATION, MAINTENANCE AND REPAIR WORK MUST BE DOCUMENTED AND MADE AVAILABLE TO THE USER.



VIKING ACCESS SYSTEMS

17595 Cartwright Rd Irvine, CA 92614

Phone 800.908.0884

Fax 949.753.1640

www.vikingaccess.com

A BRAND OF
FAAC TECHNOLOGIES